



Installation Instructions

Power Step

Automatic Retracting Running Board

www.bestop.com - We're here to help! Visit our web site and click on "Ask a Question"



Vehicle Application













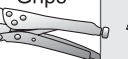

- Chevy Silverado/GMC Sierra Extended Cab
1999 and newer (6 ft.)
Part Number: 75112-01

- Chevy Silverado/GMC Sierra Crew Cab
1999 and newer (7 ft.)
Part Number: 75113-01

- Chevy Tahoe/ GMC Yukon
2001 and newer (6 ft.)
Chevy Avalanche with cladding
Cadillac Escalade
2002 and newer (6 ft.)
Part Number: 75114-01

- Chevy Suburban/GMC Yukon XL
2001 and newer (7 ft.)
Chevy Avalanche without cladding
2004 and newer (7 ft.)
Cadillac Ext
2002 and newer (7 ft.)
Cadillac ESV
2003 and newer (7 ft.)
Part Number: 75110-01

INSTALLATION TIME	SKILL LEVEL
 <p>3 Hours</p>	 <p>4 - Difficult</p>

TOOLS				
 <p>Tape Measure</p>	 <p>Flat-Head Screwdriver</p>	 <p>Phillips Screwdriver</p>	 <p>Vise Grips</p>	 <p>Power Drill</p>
1/8", 3/16", 9/32" 21/64" Drill Bits				
 <p>Ratchet</p>	 <p>Wrench 13 mm</p>	 <p>Socket 7 mm, 13 mm</p>	 <p>Allen Wrench 5 mm and 3/16"</p>	 <p>Crimp Tool</p>
 <p>Wire Cutters</p>	 <p>Wire Stripper</p>	 <p>Electrical Tape</p>	 <p>Silicone Sealant</p>	 <p>Safety Glasses</p>



! WARNING The manufacturer strongly recommends that this product be professionally installed.

! WARNING Failure to carefully follow the electrical installation steps could result in severe electrical shock which could harm the installer and/or damage the vehicle.

! WARNING This product is designed primarily to enhance the appearance of the vehicle and to shield the occupants from ordinary weather conditions. Do not rely in any way on the components of this product to contain occupants within the vehicle, or to protect against injury or death in the event of an accident. This product will not protect the occupants from falling objects. Never operate the vehicle in excess of manufacturer's specifications.

WEAR SEAT BELTS AT ALL TIMES

Read and follow, precisely, all installation instructions provided when installing product. Failure to do so may result in a poor fit and could place occupants of the vehicle in a potentially dangerous situation.

Power Step – Installation Instructions

Parts List and Hardware Identification

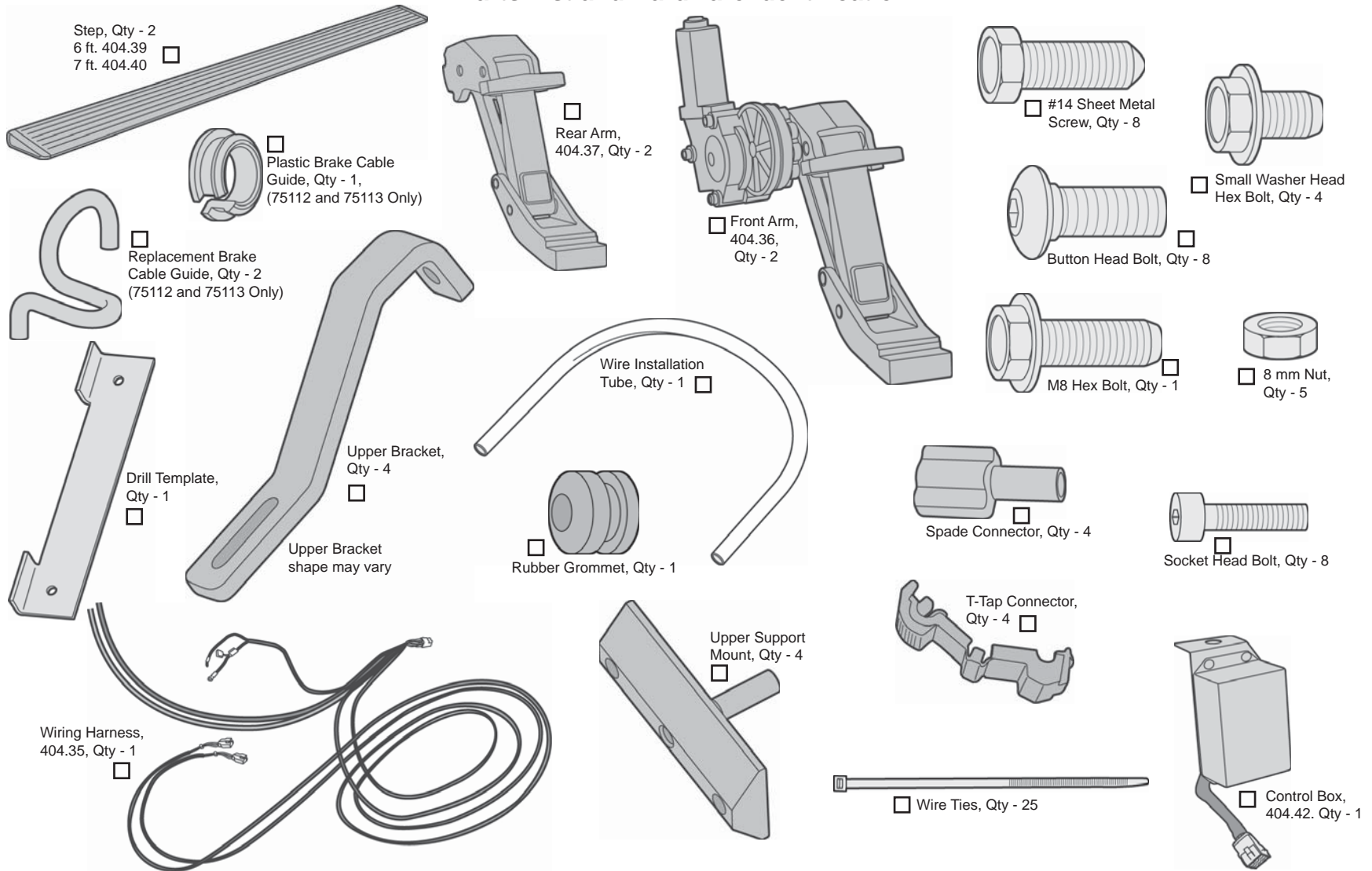

Power Step – Installation Instructions

NOTE

Steps One through Three are for Heavy Duty Trucks only. For all other vehicles skip to Step Four.

1 Heavy Duty Trucks Only Remove Brake Cable Guide(s)

Heavy Duty Short Bed

Remove the front Brake Cable Guide.

Heavy Duty Long Bed

Remove the first and third Brake Cable Guides.

2 Heavy Duty Trucks Only Install Replacement Brake Cable Guides

Install the Replacement Brake Cable Guides.

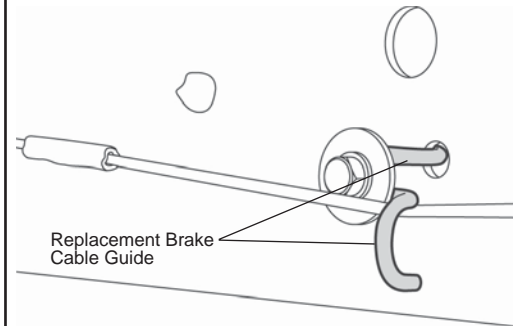

3 Heavy Duty Long Bed Only Install Plastic Brake Cable Guides

Install the Plastic Brake Cable Guide in the front hole of the rear body mount.

Replacement Brake Cable Guide

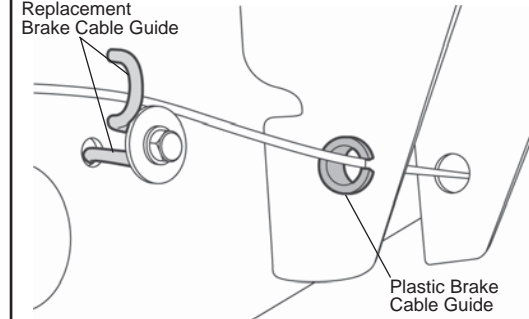

Plastic Brake Cable Guide

4 Drill Holes for Rear Arm

Locate the Drill Template in the parts kit. Place it along the sill 1/16" in front of the rear sill drain. Use vise grips to secure the Template to the sill. Drill a 1/8" pilot hole at each location in the Template. Remove the Template and drill the holes out to 21/64".

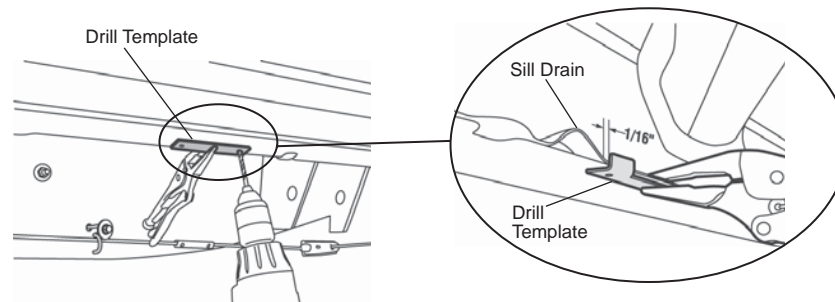

5 Drill Holes for Front Arm

Most Vehicles

Clamp the Drill Template to the pinch weld 1/8" behind the front mounting tab. Drill a 1/8" pilot hole at each location in the Template. Remove the Template and drill the holes out to 21/64".

SUV's – Driver's Side Only

Clamp the Drill Template 1/8" in front of the sill drain. Then drill the holes as above.

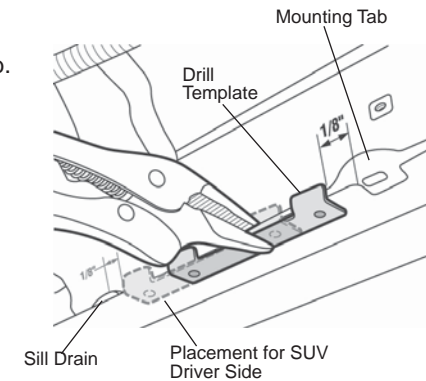

Power Step – Installation Instructions

6 Remove Step Plate and Kick Plate

Open the door. Use a flat screwdriver to pop off the Step Plate in the door opening. When the fasteners release, slide the Kick Panel out from under the seat. Do this on both sides of the vehicle.

Peel back the carpet. Move the wiring harness out of the way.

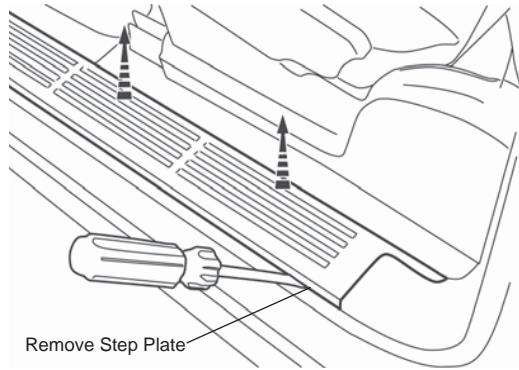

CAUTION

Make sure the wiring harness is out of the way before drilling.

7 Install Front Upper Support Mount

Use a tape measure to locate the center between each pair of holes drilled in the previous steps. Use a straight edge to draw a vertical line up the sill from this center point.

Center the Upper Support Mount on this line in the upper corner of the sill. Use the Mount as a template to drill two 1/8" pilot hole. Remove the Mount and drill two 3/16" holes. Replace the Mount and install it with two #14 Sheet Metal Screws.

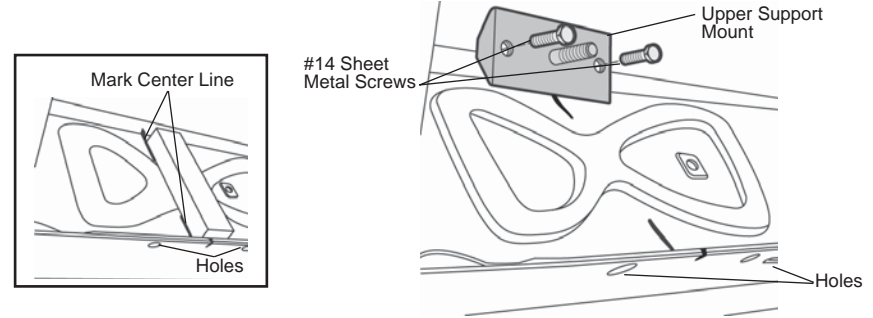

CAUTION

Make sure the wiring harness is out of the way before drilling.

8 Install Rear Upper Support Mount

Use a tape measure to locate the center between each pair of holes drilled in the previous steps. Use a straight edge to draw a vertical line up the sill from this center point.

Center the Upper Support Mount on this line in the upper corner of the sill. The rear Upper Support Mounts will be installed behind the frame support and will only require one #14 Sheet Metal Screw. Use the Mount as a template to drill a 1/8" pilot hole. Remove the Mount and drill a 3/16" hole. Replace the Mount and install it with a #14 Sheet Metal Screw.

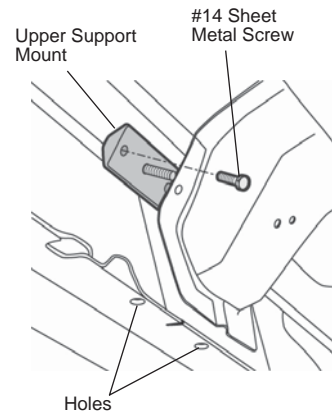

Power Step – Installation Instructions



CAUTION

Because of model year variations, should you encounter interference with wiring looms, hydraulic lines, air conditioning lines and/or cables, contact Bestop Customer Service before proceeding.

9 Install Arms and Upper Brackets

Orient the Arms so that the Arms with the motors are in front and the idler arms are in back.

Slide the hole in the Upper Bracket over the stud on the Upper Support Mount and secure it in place with an 8mm Nut. Attach an Arm to the Upper Bracket with a Small Washer Head Hex Bolt through the slot in the Upper Bracket. Mount the Arm to the sill with two Button Head Bolts. Finger tighten the fasteners at this time.

NOTE Trucks Only Important:
The motorized linkage assembly goes to the front location on the driver's side and to the rear location on the passenger side.

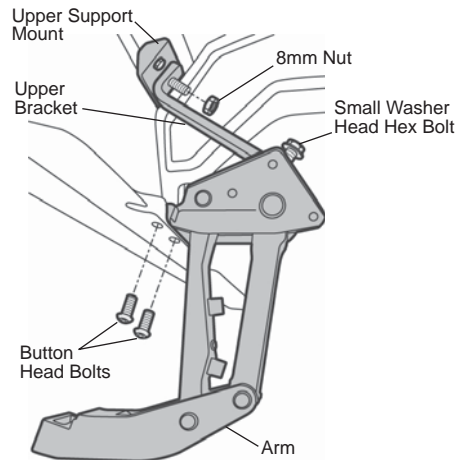

10 Install Steps

Orient the Steps on the vehicle aligning the rear of the Steps with the rear edge of the back doors. Mount the Steps to the arms. Slide the mounting T-Nut into position. Install two Socket Head Bolts to secure the Step to each Arm. Use a 3/16" Allen Wrench to tighten the bolts to 10 ft./lbs.

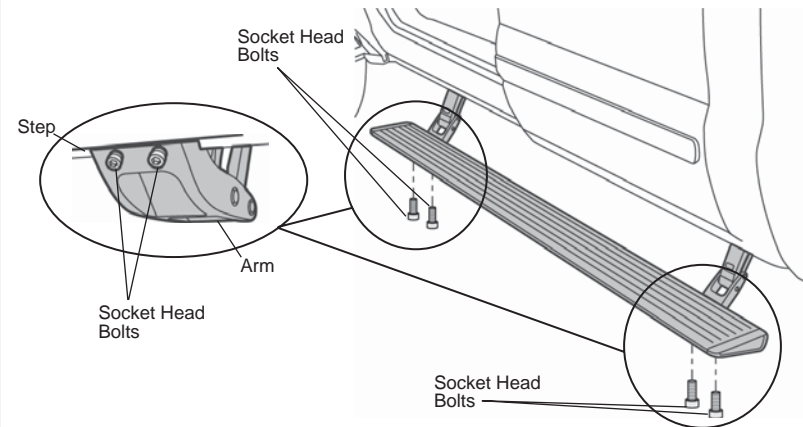

11 Adjust and Tighten Fasteners

Tighten the Button Head Bolts and Upper Nut to 16 ft./lbs. (22 Nm). Adjust the bottom edge to make sure that it is horizontal. Then tighten the Small Washer Head Bolt to 16 ft./lbs. (22 Nm).

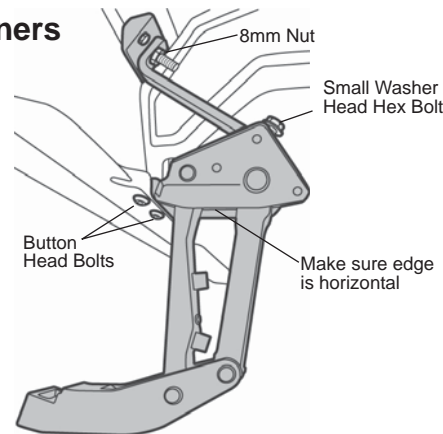

12 Install Control Box

Locate the remove the Hood Support Bolt on the Driver's side of the engine compartment. Install the M8 Hex Bolt in the hole. Place the Control Box under the ledge and use an 8mm Nut to secure it to the bolt.

Plug the Wiring Harness into the Control Box. Make sure that the Locking Tabs engage.

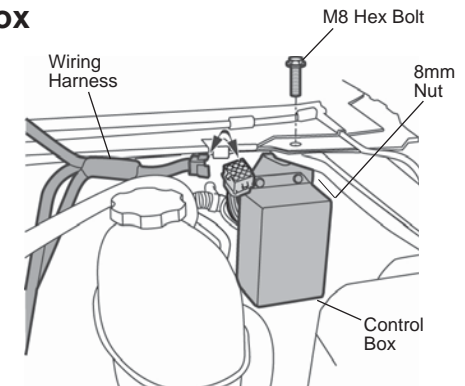

Power Step – Installation Instructions

! WARNING Remove the fuse from the Wiring Harness.

13 Remove Fuse from Wiring Harness

Remove the fuse from the Wiring Harness. Failure to do so could result in severe electrical shock which could harm the installer and/or damage the vehicle.

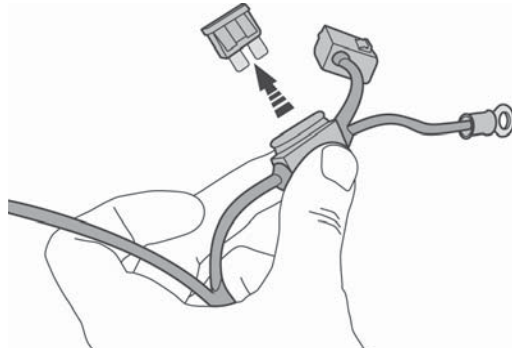

! CAUTION Do not ground the wrench when engaged with the Nut

14 Secure Leads

Attach the red Power Lead wire to the positive lead in the junction box.
Attach the Ground Lead to the junction box mounting bracket.

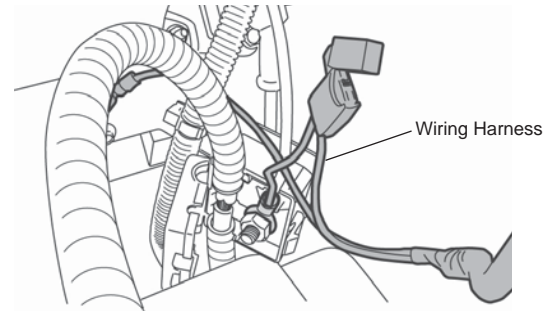

15 Secure Wiring Harness

Route the longer leg of the harness across the front of the engine compartment and down to the motor on the passenger's side step. Route the shorter leg to the motor on the driver's side step. Use the wire ties in the parts kit to secure the harness to the cowling clips on the fire wall in the engine compartment. Secure the harness to the frame in the wheel wells.

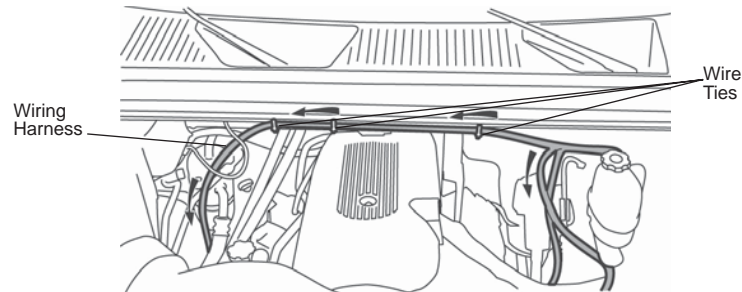

16 Install Wires – Driver's Side

Puncture the grommet in the floor panel near the front door and thread the two wires from the Wiring Harness through the firewall.

Plug the Wiring Harness into the motor on the Front Arm.

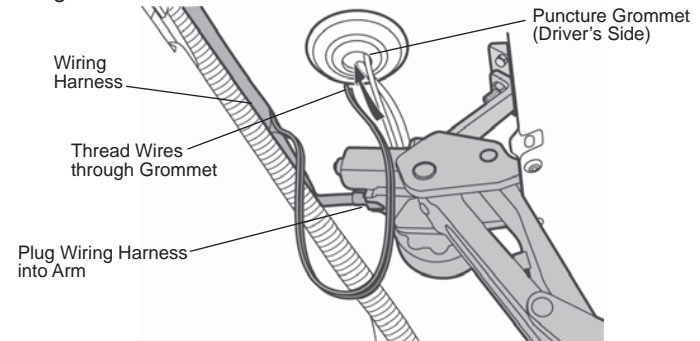

Power Step – Installation Instructions

17 Install Wires – Passenger’s Side

Drill a 9/32" hole in the floor panel and install the Rubber Grommet from the parts kit. Then thread the wires from the harness through the Grommet.

Plug the Wiring Harness into the motor on the Front Arm.

Pull the wires up through the floor on both sides and seal all holes with Silicone Sealant.

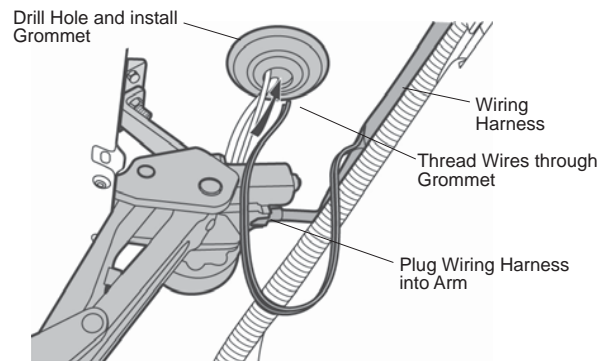

19 Remove Door Trim

Remove the plastic trim on the door near the mirror attachment.

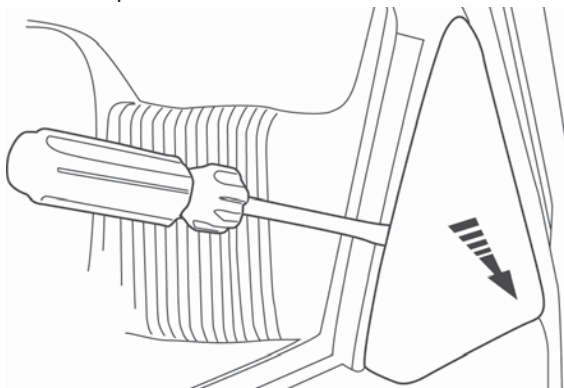

18 Driver’s Side Install T-Tap and Spade Connectors

Carefully remove the wrap on the wiring harness in the door opening. Locate the light blue wire with a black stripe. Install a T-Tap Connector on this wire.

Locate the shorter wire threaded through the floor. Install a Spade Connector on it. Connect the Spade Connector to the T-Tap Connector.

Passenger’s Side Install T-Tap Connector and Spade Connectors

Carefully remove the wrap on the wiring harness in the door opening. Locate the green wire with a black stripe. Make sure that you are behind the “T” junction that leads under the seat and install a T-Tap Connector on this wire.

Locate the shorter wire threaded through the floor. Install a Spade Connector on it. Connect the Spade Connector to the T-Tap Connector.

NOTE

Note: On the passenger side, it is very important that you place the T-Tap Connector behind the junction that leads under the seat.

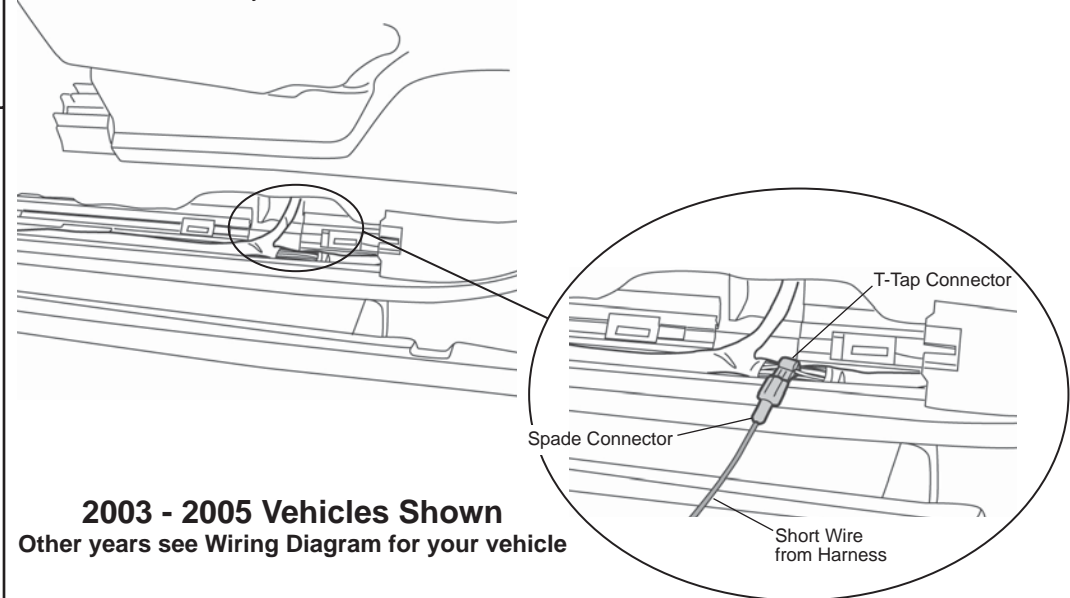

Power Step – Installation Instructions

20 Remove Door Panel

Pry off the door lock and remove the bolts.

Pry off the door handle plate and any remaining panel fasteners. Remove the door light and door panel. Unplug the switch plate.

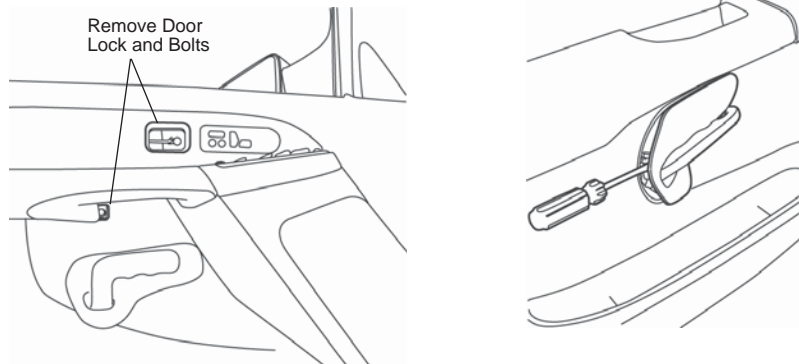

21 Thread Long Wire from Harness

Pull back the door weather guard to access the speaker. Pry out the speaker and unplug it.

Locate the plastic Wire Installation Tube in the parts kit. Thread the tube into the hole in the door, through the accordion between the door and the vehicle. Then thread the longer wire from the Wiring Harness through the tube into the door. Once the wire is in place, remove the tube from the door side.

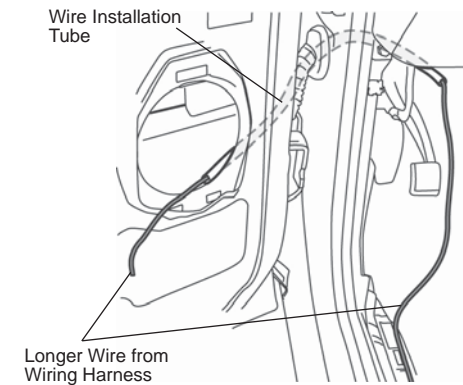

22 Route Connecting Wire in Door

Thread the longer wire from the Wiring Harness along the path of the Wiring Harness that goes to the switch plate in the door.

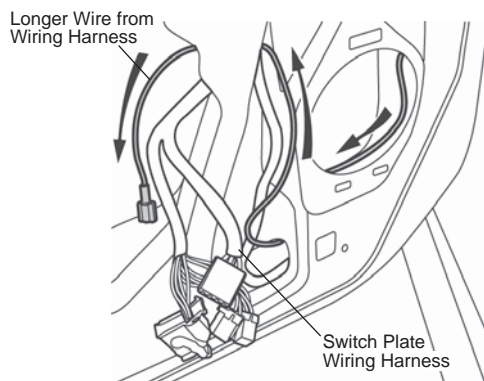

23 Driver's Side Install T-Tap Connector

Locate the Gray Wire with a Black Stripe in the Switch Plate Wiring Harness. Install a T-Tap Connector on this wire. Install a Spade Connector on the Connecting Wire and connect it to the T-Tap Connector.

Passenger's Side Install T-Tap Connector

Locate the Black Wire with a White Stripe in the Switch Plate Wiring Harness. Install a T-Tap Connector on this wire. Install a Spade Connector on the Connecting Wire and connect it to the T-Tap Connector.

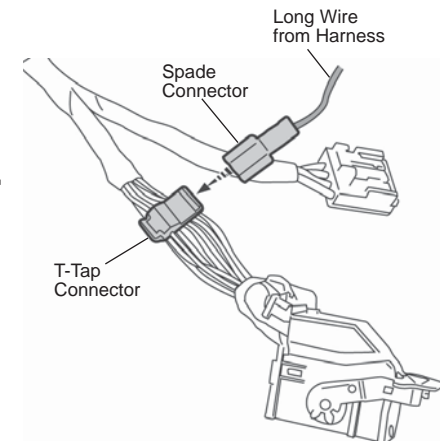

2003 - 2005 Vehicles Shown
Other years see Wiring Diagram for your vehicle

Power Step – Installation Instructions



CAUTION

Unsecured wire may interfere with window operation.

24 Secure Wires

Secure the wire to the Switch Plate Wiring Harness with Wire Ties and Electrical Tape.

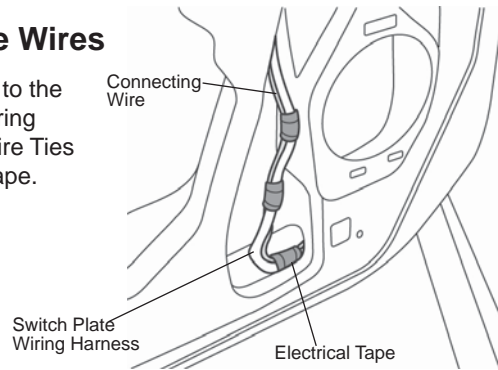

CAUTION

A plug lever that is not fully open may interfere with window and power step operation.

25 Plug Lever Check

Make sure that the plug lever is fully opened before reattaching the switch plate. Reassemble the door.

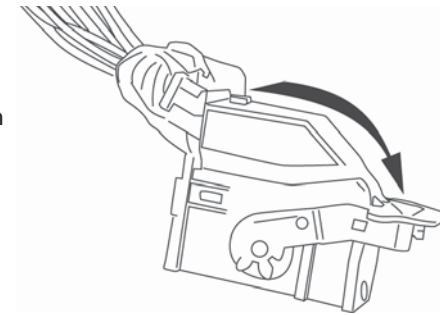

26 Reinstall Fuse

Reinstall the fuse in the harness.

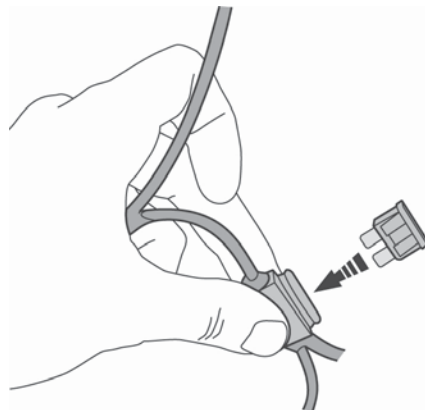

27 Test Doors

Open the doors to make sure that the Step drops into position on each side of the vehicle. Check that all bolts and fasteners are securely tightened.

NOTE

If the Step position is not even, repeat the adjustment from Step 10.

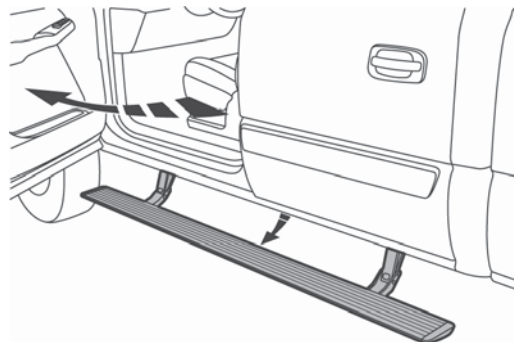

28 Reassemble Doors

Once you have checked that the Steps function properly, reassemble the doors and reinstall the Kick Plates and Step Plates on both sides of the vehicle.

Power Step – Installation Instructions

Limited Warranty

We warrant our product to be free from defects in material and workmanship, for the terms specified below, provided there has been normal use and proper maintenance. This warranty applies to the original purchaser only. All remedies under this warranty are limited to the repair or replacement of any item or items found by the factory to be defective within the time period specified.

If you have a warranty claim, first you must call our factory at the number below for instructions. You must retain proof of purchase and submit a copy with any items returned for warranty work. Upon completion of warranty work, if any, we will return the repaired or replaced item or items to you freight prepaid. Damage to our products caused by accidents, fire, vandalism, negligence, misinstallation, misuse, Acts of God, or by defective parts not manufactured by us, is not covered under this warranty.

THE WARRANTY TIME PERIOD IS AS FOLLOWS: ALL "SOFT GOODS" MANUFACTURED BY OUR COMPANY (USING PRIMARILY VINYL, PLASTICS, AND/OR FOAM): ONE YEAR FROM DATE OF PURCHASE.

ANY IMPLIED WARRANTIES OF MERCHANTABILITY AND/OR FITNESS FOR A PARTICULAR PURPOSE CREATED HEREBY ARE LIMITED IN DURATION TO THE SAME DURATION AND SCOPE AS THE EXPRESS WRITTEN WARRANTY. OUR COMPANY SHALL NOT BE LIABLE FOR ANY INCIDENTAL OR CONSEQUENTIAL DAMAGE.

Some states do not allow limitations on how long an implied warranty lasts, or the exclusion or limitation of incidental or consequential damages, so the above limitations or exclusions may not apply to you.

This warranty gives you specific legal rights, and you may also have other rights which vary from state to state.



For further information or request for warranty work, please contact:
Bestop Inc. Customer Service
(800) 845-3567
(303) 465-1755