



Installation Instructions

Power Step













Automatic Retracting Running Board

Vehicle Application

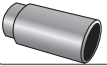
- **Ford F150 Super Crew Cab**
2004 and newer (6.5 ft.)
Part Number: 75105-01

- **Lincoln Mark LT**
2006 and newer (6.55 ft.)
Part Number: 75105-01
- **Ford F150 Extended Cab**
2004 and newer (6 ft.)
Part Number: 75109-01

www.bestop.com - We're here to help! Visit our web site and click on "Ask a Question"

INSTALLATION TIME		SKILL LEVEL	
 <p>3 Hours</p>		 <p>4 - Difficult</p>	
TOOLS			
 <p>Tape Measure</p>	 <p>Flat-Head Screwdriver</p>	 <p>Phillips Screwdriver</p>	 <p>Wrench 13 mm</p>
			 <p>Socket 13 mm</p>
 <p>Allen Wrench 3/16"</p>	 <p>Crimp Tool</p>	 <p>Wire Cutters</p>	 <p>Wire Stripper</p>
 <p>Electrical Tape</p>			
 <p>Safety Glasses</p>			



! WARNING The manufacturer strongly recommends that this product be professionally installed.

! WARNING Failure to carefully follow the electrical installation steps could result in severe electrical shock which could harm the installer and/or damage the vehicle.

! WARNING This product is designed primarily to enhance the appearance of the vehicle and to shield the occupants from ordinary weather conditions. Do not rely in any way on the components of this product to contain occupants within the vehicle, or to protect against injury or death in the event of an accident. This product will not protect the occupants from falling objects. Never operate the vehicle in excess of manufacturer's specifications.

WEAR SEAT BELTS AT ALL TIMES

Read and follow, precisely, all installation instructions provided when installing product. Failure to do so may result in a poor fit and could place occupants of the vehicle in a potentially dangerous situation.

Power Step – Installation Instructions

Parts List and Hardware Identification

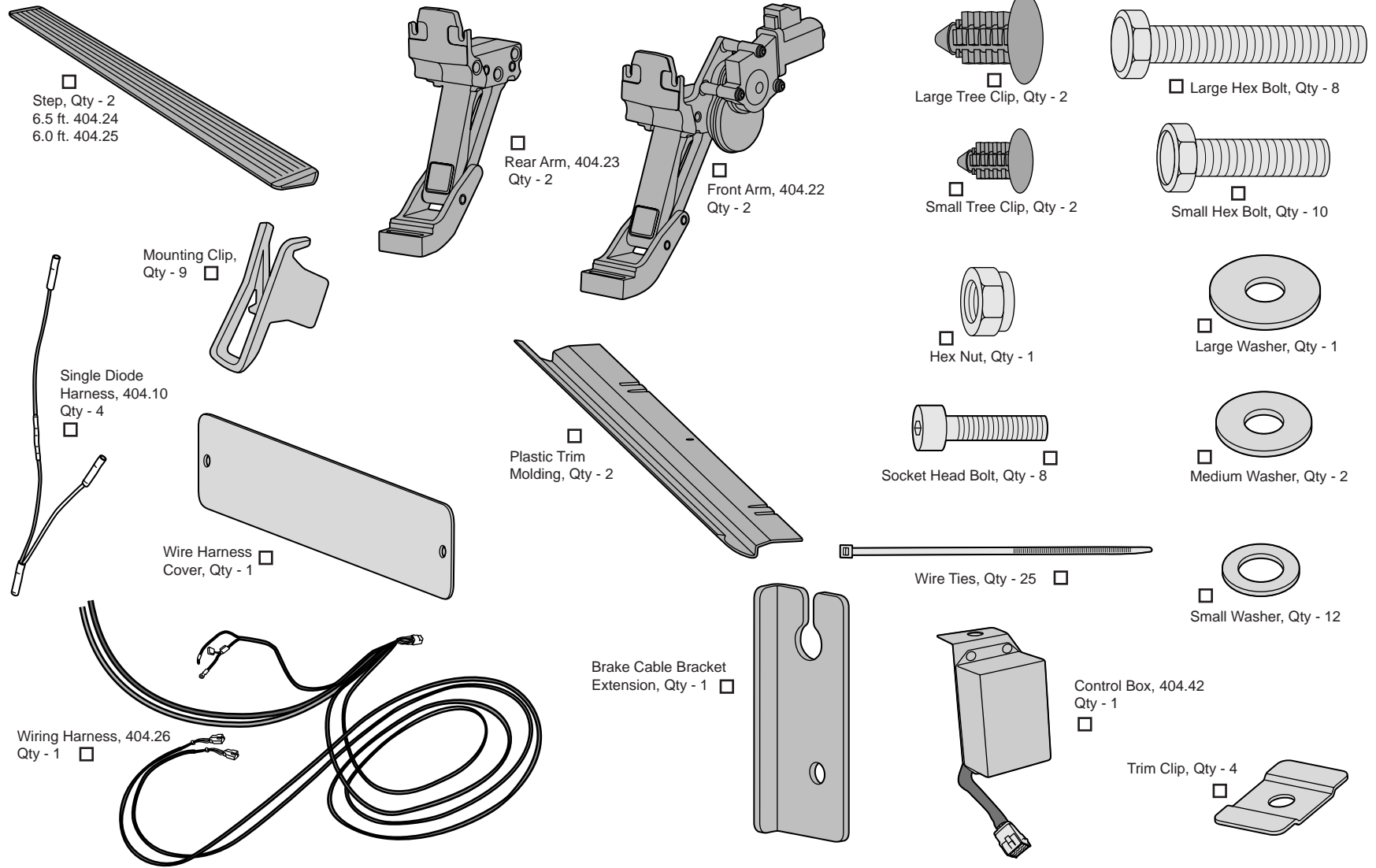

DO NOT force these bolts. If you feel resistance, rock the bow back and forth to help align the holes.

Power Step – Installation Instructions

1 Remove Original Wire Harness Cover and Install New Wire Harness Cover

Locate the Wire Harness Cover attached to the frame under the door on the driver's side of the vehicle. Remove the two Tree Clips that secure the cover to the frame and remove the cover.

Bend the new Wire Harness Cover supplied in the parts kit into position and use the two Large Tree Clips from the parts kit to attach it to the same holes in the frame.

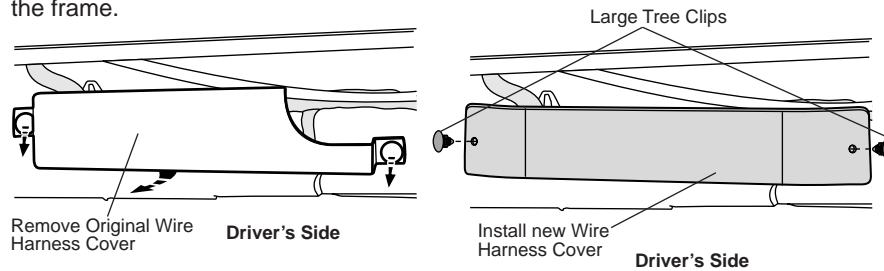

2 Install Brake Cable Bracket Extension

Locate the Brake Cable Bracket Extension in the parts kit.

Slide the brake cable out of the Brake Cable Bracket on the vehicle. Use a Small Hex Bolt, the Large Washer and the Hex Nut to attach the Brake Cable Bracket Extension to the Brake Cable Bracket through the hole for the brake cable. Raise the brake cable into the opening in the Brake Cable Bracket Extension.

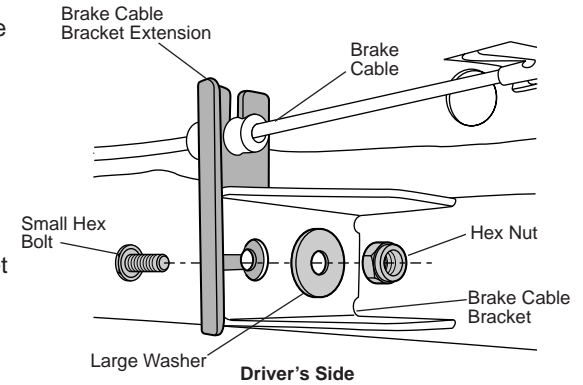

NOTE When you raise the brake cable into position, first pull downward to create slack.

3 Install Mounting Clips - Driver's Side

Counting from the front, locate the first (1st) and last set of mounting holes on the inner sill. Use a Small Hex Bolt and a Small Washer to install a Mounting Clip on each side of each hole. Do not tighten the bolts at this time.

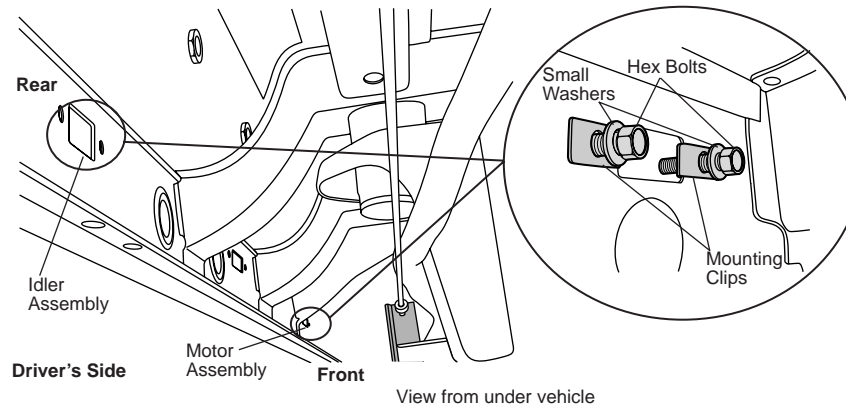

Power Step – Installation Instructions

4 Install Arms and Trim Clip - Driver's Side

Orient the Front and Rear Arms so the platforms face outside the vehicle to support the Step and with the motor on the Front Arm toward the front of the vehicle. Slip the notches in the Arms under the bolts and washers installed in Step One. Tighten these bolts to 16 ft./lbs (22Nm).

Secure the bottom of the Arms with two Small Hex Bolts and one Small Washer and a Trim Clip over the rear bolt on the Rear Arm and over the front bolt on the Front Arm. Do not tighten the bolts yet.

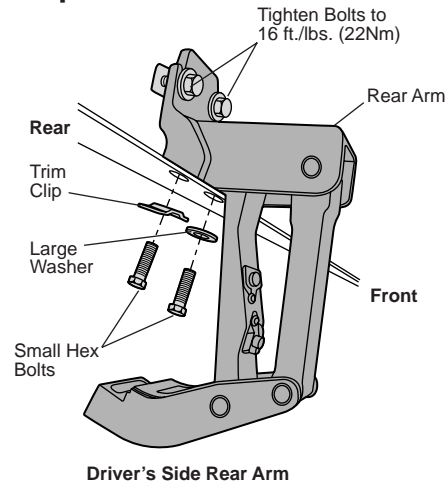

NOTE If the sheet metal holes are misaligned, you may need to file off the edge of the sheet metal.

5 Install Plastic Trim Molding

Slide the Plastic Trim Molding over the Trim Clips installed in Step Four. Tighten the Front and Rear Arm Hex Bolts to 16 ft./lbs. (22Nm). Locate the hole in the center of the molding. Use a Small Tree Clip and a Medium Washer to secure the center of the molding.

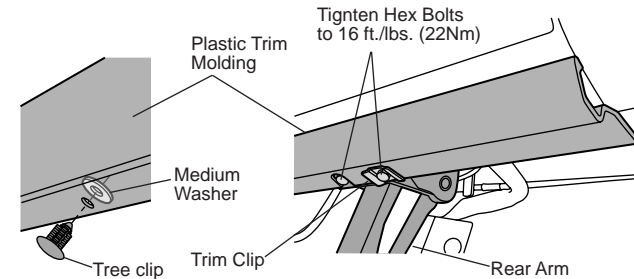

6 Install Steps

Slide the Step onto the arms so that the T-Nut aligns with the holes in the arms.

Install four Socket Head Bolts. Use a 3/16" Allen Wrench to tighten the bolts to 10 ft./lbs. (13.5 Nm).

Repeat Steps One through Six on the passenger side of the vehicle.

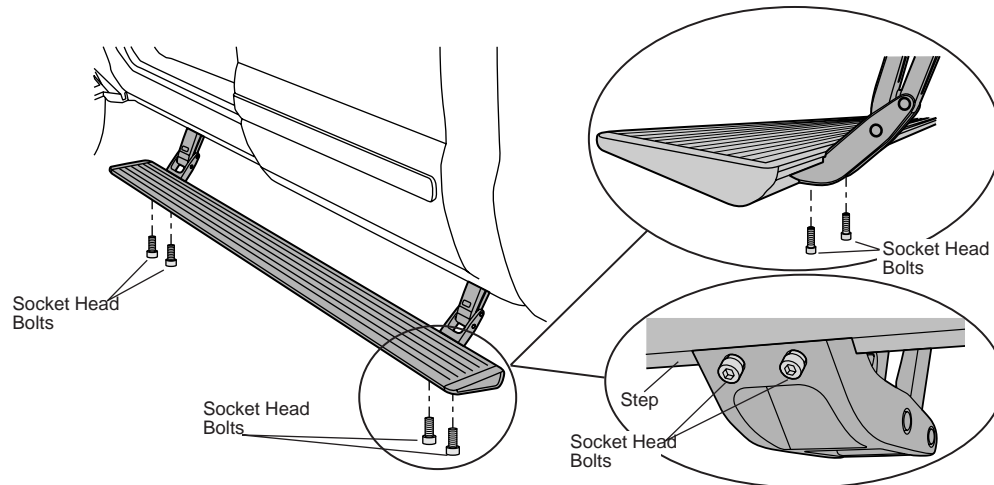

Power Step – Installation Instructions

7 Install Control Box and Wiring Harness

Remove the fan shroud.

Remove the bolt of the hood adjustment stop.

Place the Control Box under the brace so that the hole in the flange on the Control Box lines up with the hole in the brace. Reinstall the hood adjustment stop bolt to attach the Control Box to the brace. Tighten the bolt to 5 ft./lbs (6.5 Nm).

Route the Wiring Harness down and toward the Control Box. Attach the harness to the Control Box. Make sure that the Locking Tabs latch on the Wiring Harness connector.

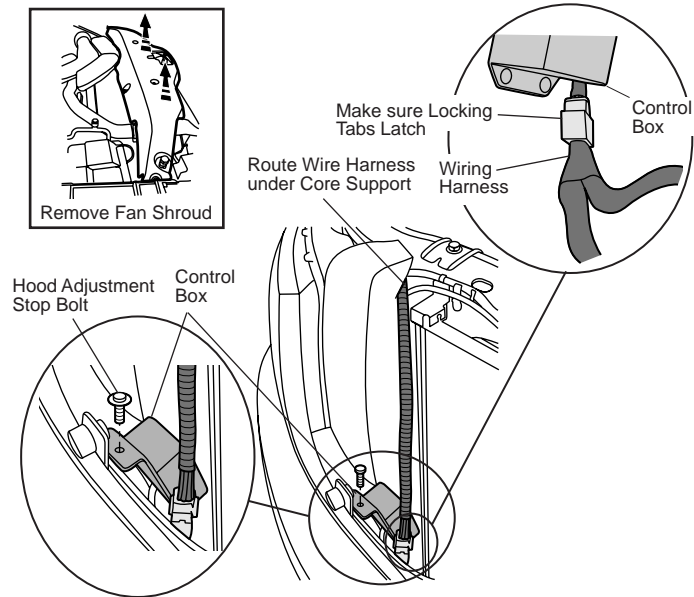

WARNING

Remove the fuse from the Wiring Harness.

8

Remove Fuse from Wiring Harness

Remove the fuse from the Wiring Harness. Failure to do so could result in severe electrical shock which could harm the installer and/or damage the vehicle.

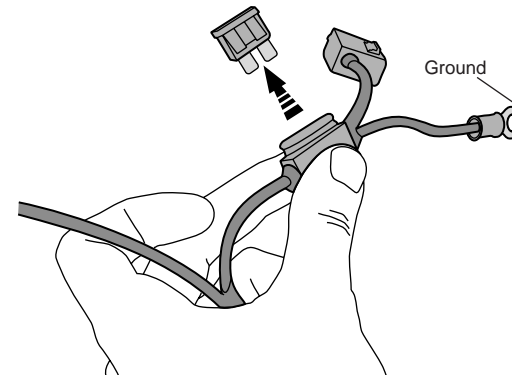

Power Step – Installation Instructions

9 Attach Wiring Harness to Battery

Attach the ground wires on the Wiring Harness to the positive and negative terminals on the battery. Route the longer leg of the harness across the front of the engine compartment and down to the motor on the driver's side step. Route the shorter leg to the motor on the passenger's side step. Use the wire ties in the parts kit to secure the harness out of the way.

Reinstall the Fan Shroud.

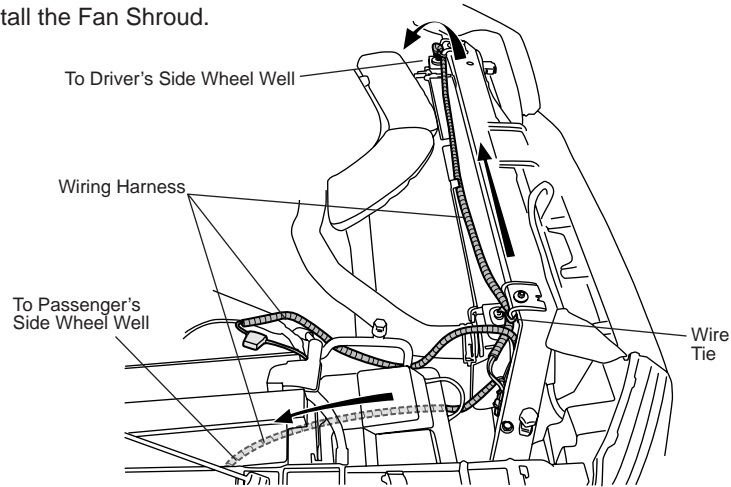

10 Install Trigger Wires

Puncture the grommet in the firewall and thread the four Trigger Wires from the Wiring Harness through the firewall.

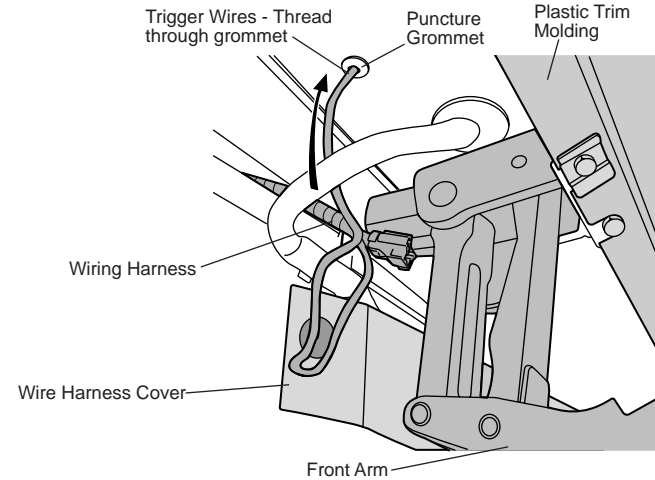

11 Remove Driver's Side Front and Rear Step Plates

Remove the Step Plates from the front and rear door openings on the driver's side. Roll back the carpet to access the wiring underneath.

Pull the wires from the grommet along the door opening next to the wire harness to the rear door opening.

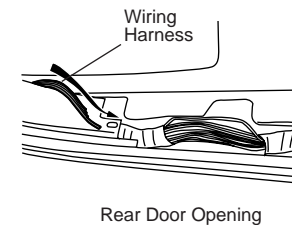
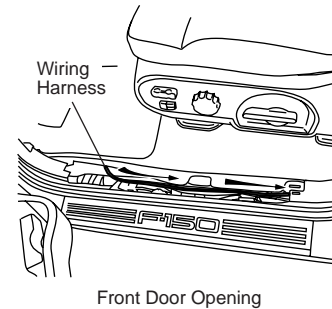
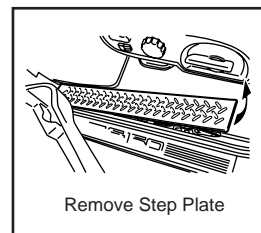

Power Step – Installation Instructions

12 Install Single Diode Harnesses

Splice the Trigger Wires as shown in the Wiring Diagram that applies to your vehicle.

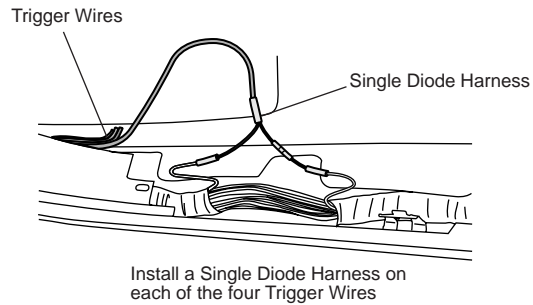

13 Plug Wiring Harness into Step Motors

Plug the harness into the Step Motor.

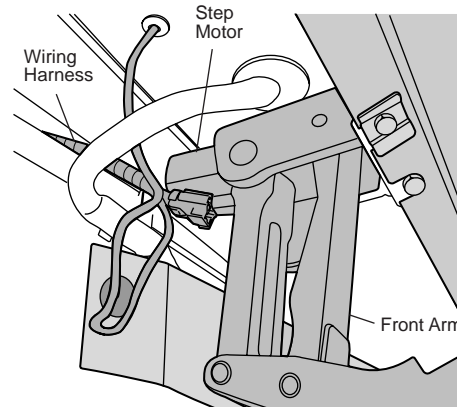

14 Reinstall Fuse

Reinstall the fuse in the harness.

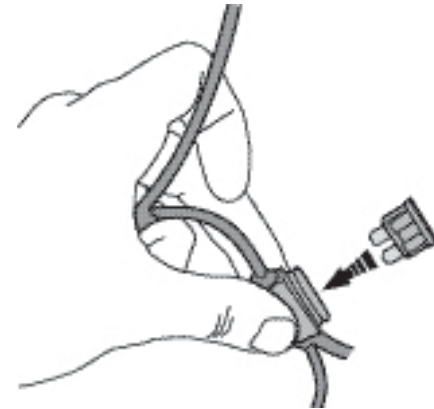

15 Test Doors

Open the doors to make sure that the Step drops into position on each side of the vehicle.

Check that all bolts and fasteners are securely tightened.

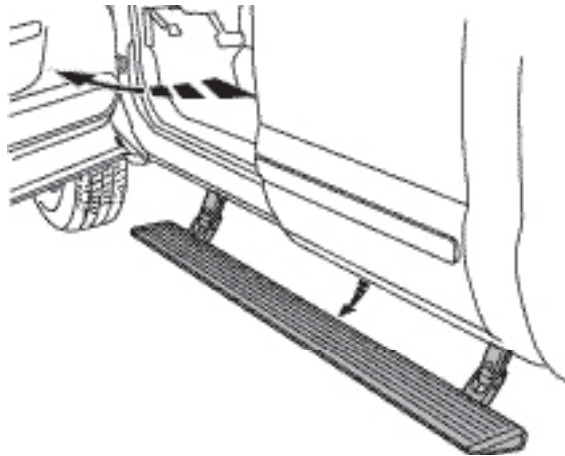

16 Reinstall Step Plates

Once you have checked that the Steps function properly, reinstall the Step Plates.

Power Step – Installation Instructions

Limited Warranty

We warrant our product to be free from defects in material and workmanship, for the terms specified below, provided there has been normal use and proper maintenance. This warranty applies to the original purchaser only. All remedies under this warranty are limited to the repair or replacement of any item or items found by the factory to be defective within the time period specified.

If you have a warranty claim, first you must call our factory at the number below for instructions. You must retain proof of purchase and submit a copy with any items returned for warranty work. Upon completion of warranty work, if any, we will return the repaired or replaced item or items to you freight prepaid. Damage to our products caused by accidents, fire, vandalism, negligence, misinstallation, misuse, Acts of God, or by defective parts not manufactured by us, is not covered under this warranty.

THE WARRANTY TIME PERIOD IS AS FOLLOWS: ALL "SOFT GOODS" MANUFACTURED BY OUR COMPANY (USING PRIMARILY VINYL, PLASTICS, AND/OR FOAM): ONE YEAR FROM DATE OF PURCHASE.

ANY IMPLIED WARRANTIES OF MERCHANTABILITY AND/OR FITNESS FOR A PARTICULAR PURPOSE CREATED HEREBY ARE LIMITED IN DURATION TO THE SAME DURATION AND SCOPE AS THE EXPRESS WRITTEN WARRANTY. OUR COMPANY SHALL NOT BE LIABLE FOR ANY INCIDENTAL OR CONSEQUENTIAL DAMAGE.

Some states do not allow limitations on how long an implied warranty lasts, or the exclusion or limitation of incidental or consequential damages, so the above limitations or exclusions may not apply to you.

This warranty gives you specific legal rights, and you may also have other rights which vary from state to state.



For further information or request for warranty work, please contact:
Bestop Inc. Customer Service
(800) 845-3567
(303) 465-1755