

# **ROLL·N·LOCK**®

*The most advanced cargo containment system made*

*Cover your cargo with  
**ROLL·N·LOCK**®...*

*Control it with  
**CARGO MANAGER**®.*





The most advanced retractable truck bed cover made

## Innovation

ROLL-N-LOCK® M-Series... the most advanced retractable truck bed cover made, has redefined the rules for truck bed security. From its retractable function, which permits opening or closing in literally seconds, to its rigid, vinyl-over-aluminum laminated construction, this hybrid cover offers everything other covers do not. There are no snaps to manipulate, there is no roll or bundle to lash down or stow, no cross bars to negotiate, no fabric shrinkage to struggle with and - best of all - no worries about the security of your cargo. The ROLL-N-LOCK® retractable bed cover...by far the most sophisticated and versatile truck bed cover made.

## Quality

What sets ROLL-N-LOCK®'s curtain construction apart from the competition is not just the superior quality of our vinyl surface material, but also the design of the slatted aluminum substrate which supports the vinyl. Each ROLL-N-LOCK® slat is rotatively joined by an interlocking hinge. It is this unique contoured hinge geometry that lends

ROLL-N-LOCK® its strength, roll compactness and quiet smooth non-binding movement. Close examination of the ROLL-N-LOCK® hinge in the flat position reveals the fact that each slat is inseparably locked together, yet when rotated, no metal to metal contact occurs.

Hence, ROLL-N-LOCK®'s strength of design and smoothness of operation.



Contoured design provides smooth frictionless rotation.

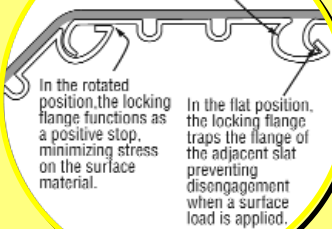

## Unique Construction

Contoured design provides smooth frictionless rotation. In the rotated position, the locking flange functions as a positive stop, minimizing stress on the surface material. In the flat position, the locking flange traps the radius of the adjacent slat preventing disengagement when a surface load is applied.

U.S. Patent No. **6,113,176**  
Canada Patent No. **Pending**



800-952-7655



U.S. Patent No.  
**5,350,213**  
Canada Patent No.  
**2,123,616**



## Features

- **Clamp-On Installation**

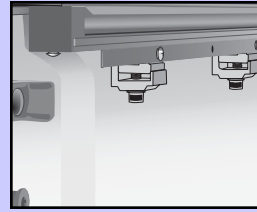

Install your *ROLL-N-LOCK*<sup>®</sup> truck bed cover without drilling! Our patented clamp-on track design makes the job simple and secure, with no need to put holes in most truck beds.

- **Smallest Housing**



Compact all-aluminum housing allows more room for storage in the truck bed.

- **Torsion Spring Equipped**



*ROLL-N-LOCK*<sup>®</sup> uses a heavy-duty torsion spring, contained in a compact aluminum reel, for the ultimate in strength and durability.

- **Multiple Latching Positions**

With just a turn of the lock-lever, your *ROLL-N-LOCK*<sup>®</sup> bed cover slides open. As you pull the cover back using the convenient built-in pull strap, the ratchet-style locking mechanism latches in place at  $\frac{1}{4}$ ,  $\frac{1}{2}$ , and  $\frac{3}{4}$  or fully closed positions. Simple!

- **Built-In Tailgate Lock**



Keep your cargo safe with *Roll-N-Lock*<sup>®</sup>'s patented built-in tailgate locking system. Our positive locking system locks the tailgate and bed cover simultaneously for the most secure system possible in a retractable bed cover application.

- **Key Slot Cover**



For the colder regions, we have developed a key slot cover to prevent water from entering the lock mechanism and freezing.

• Ship Via



# Exclusive Features:

- **Built-In Tailgate Lock**

While other retractable covers require add-on accessories to secure the tailgate, *Roll•N•Lock*® offers a patented built-in tailgate locking feature for trucks without locking tailgates or for those customers that simply desire added security. Similar to the door on your truck, this feature automatically latches when closed or can be locked when absolute security is required. Standard on every *Roll•N•Lock*® is an auto-positioning and locking feature which allows the operator to conveniently locate the cover in a partially closed position or to lock it in the fully closed position. This entire mechanism is controlled by a central lock lever with key activated locking.

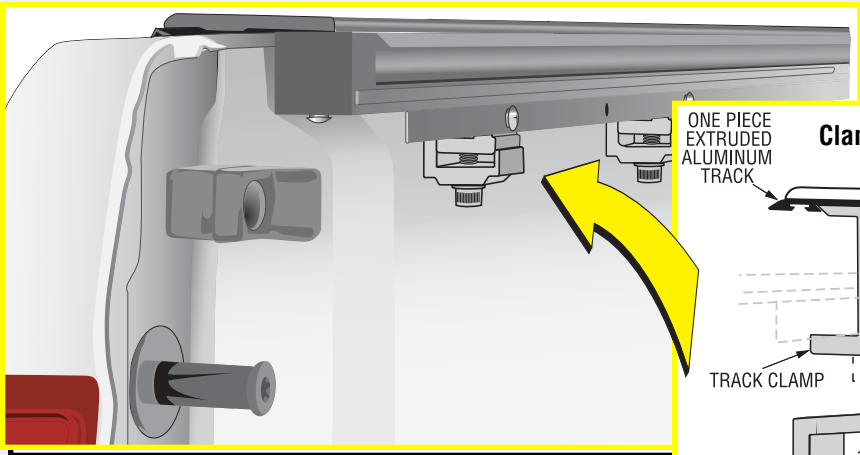

U.S. Patent No.  
**5,251,950**

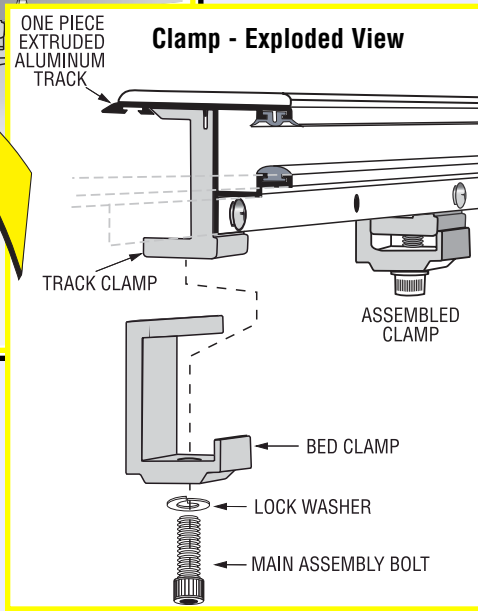

- **Clamp-On Track Design**

This patented feature eliminates the need to drill holes in the bed rails on the vast majority of trucks. Unlike other systems which are only screwed to the down flange of the bed rail, the *ROLL•N•LOCK*® system clamps to the main structure of the rail, providing a more positive and stable means of connection. This clamping action also serves to compress the track's integral trim gasket to the bed rail surface, reducing the possibility of perimeter leakage and providing a clean termination of track flange to bed rail. The track's one piece cross-section design channels water run-off forward to the housing collector or back to the tailgate, further reducing or eliminating perimeter leakage common to alternate two piece assemblies.

- **Key Slot Cover**

For the ice and snow regions we have developed a key slot cover to prevent water from entering the lock mechanism and freezing.

- **Key is non-directional for convenience**

- **Finger Insulator Grip**

For very sunny and hot climates, we have developed a finger insulator grip, which allows the operator to grasp the handle without burning his or her fingertips.



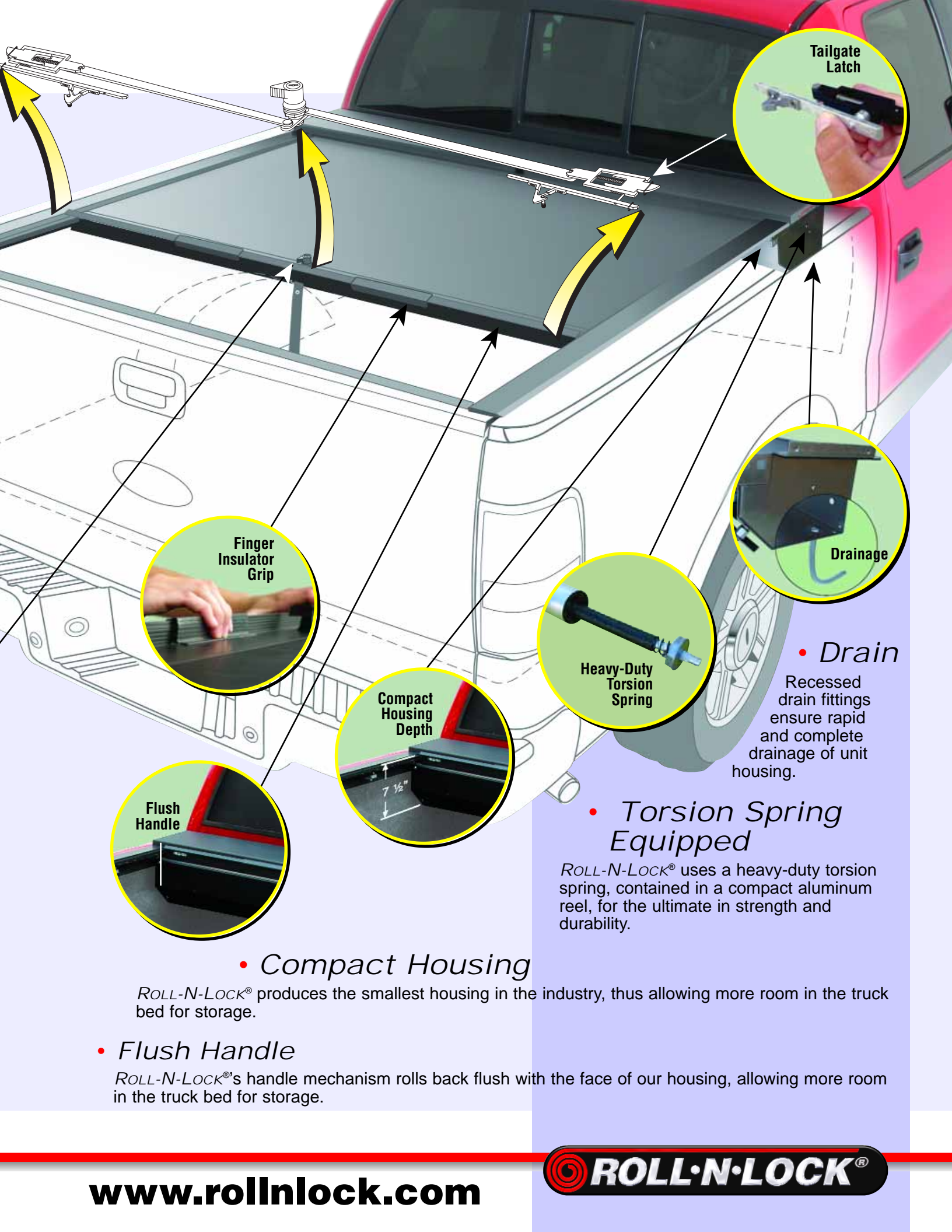

Tailgate Latch

Finger Insulator Grip

Compact Housing Depth

Flush Handle

Heavy-Duty Torsion Spring

Drainage

• *Drain*

Recessed drain fittings ensure rapid and complete drainage of unit housing.

• *Torsion Spring Equipped*

ROLL-N-LOCK® uses a heavy-duty torsion spring, contained in a compact aluminum reel, for the ultimate in strength and durability.

• *Compact Housing*

ROLL-N-LOCK® produces the smallest housing in the industry, thus allowing more room in the truck bed for storage.

• *Flush Handle*

ROLL-N-LOCK®'s handle mechanism rolls back flush with the face of our housing, allowing more room in the truck bed for storage.

# CARGO / MANAGER®

The first & only movable bed divider



This dynamic product combination affords truck owners not only the ability to cover and secure the contents of the truck bed, but also prevents objects from shifting or moving about the bed when stopping or turning abruptly.



*CARGO MANAGER*®, an optional companion product for *ROLL•N•LOCK*®, is a movable bed divider that can be positioned at any point along the length of the truck bed to manage and contain lightweight cargo. Controlled from the driver's side, *CARGO MANAGER*® is positioned by simply squeezing the linkage control levers. *CARGO MANAGER*®'s spring activated linkage then automatically pins the divider to each side track in the next nearest slot in the direction of movement (slots on 3" centers).



800-952-7655



U.S. Patent No.  
**6,629,807**  
Canada Patent No.  
**Pending**

- *Easy Positioning Feature*

*CARGO MANAGER*<sup>®</sup>'s spring-loaded control levers, located on the driver's side of the divider, enables the divider to be conveniently positioned every 3" along the bed length, without the necessity of walking to both sides of the truck.

- *Lateral Tie-Offs*

Laterally adjustable tie-offs and two bungee cords permit easy securing of any size object, from tool boxes to grocery bags.

- *Flip-Up Feature*

*CARGO MANAGER*<sup>®</sup>'s flip-up feature allows the divider to rotate 90 degrees, holding it parallel to, and 12" above, the bed floor. This is accomplished by simply depressing stops located at the ends of each track, rolling the divider back to allow the rear wheels to exit the tracks, rotating the divider 90 degrees and hanging it on the hooks provided. Long objects, such as ladders or lumber, may then be easily loaded under the divider.

- *Unobstructed Loading*

*CARGO MANAGER*<sup>®</sup> quickly pivots up and out of the way for most loading chores. It can be easily and quickly removed for loading larger items, like appliances, which cannot slide underneath. It's convenient, easy, and versatile!

- *Easy Removal*

Weighing only 11 pounds, *CARGO MANAGER*<sup>®</sup> can be easily removed when the entire bed space is required for hauling.

- *Will Ship Via*



# **ROLL·N·LOCK**<sup>®</sup>

*The most advanced cargo containment system made*



## **ROLL·N·LOCK**<sup>®</sup>

**Roll-N-Lock Corporation**  
915 South Dixie Highway E  
Pompano Beach, FL 33060  
Ph. (954) 785-7655  
[www.rollnlock.com](http://www.rollnlock.com)

