



Permanent Mount Rack with Hidden Hardware Installation Instructions



Package Contents:

- 8 - Permanent Mounting Bracket
- 8 - U-Clips
- 8 - 1/4-20 x 1 -1/4" Carriage Bolts
- 8 - 1/4-20 Nuts with Integral Lock Washer
- 4 - 1/4-20 x 1-1/2" Button Head Screw
- 4 - 1/4-20 x 5/8" Button Head Screw
- 4 - 1/4-20 x 9/16" Narrow Shoulder Button Head Screw
- 4 - Permanent Mount Pad
- 4 - Bracket Cover Cap
- 4 - End Cap
- 2 - Crossbars with Feet
- 1 - Hex Key
- 1 - Foot Template Sheet

1. Positioning Crossbars on Roof

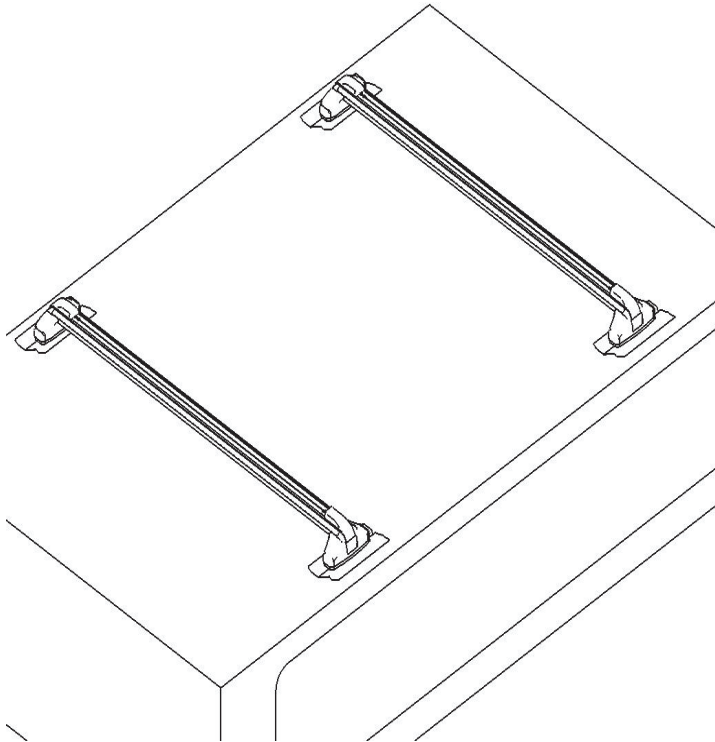

Position front and rear crossbars on roof.

Place masking tape on roof directly under each crossbar foot.

Outline base of feet on tape using a marker or pen.

2. Foot Template

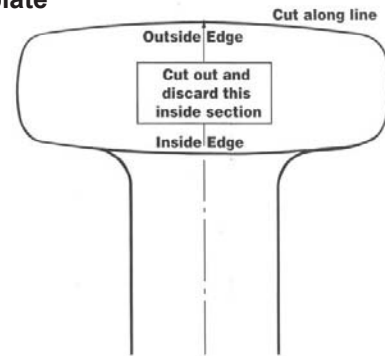

Cut out the template (see attached page) and place on each outline.

Place a mounting bracket in the inside cutout section and mark the center of the square openings of the bracket with a center punch.

Remove masking tape from the roof.

3. Bracket Assembly

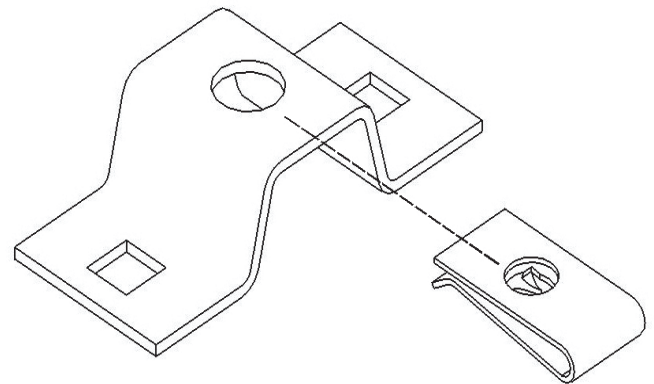

Slide the U-Clip onto the bracket as shown above.

NOTE: The curved section of the U-Clip must face downward.

Repeat until all 8 brackets are assembled.

4. Mounting Brackets to Roof

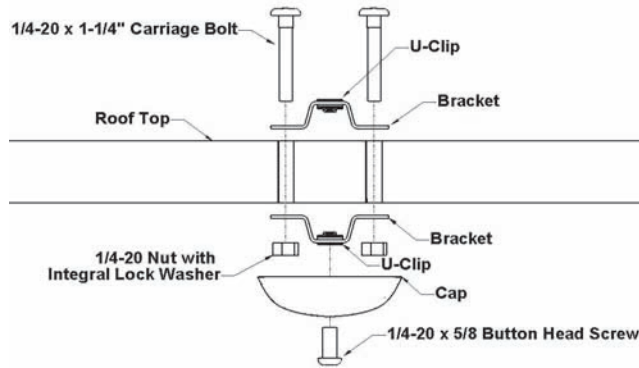

Using the marks from the center punch from Step 2, drill two 5/16" holes perpendicular through the roof.

Place assembled bracket from step 3 on top of roof and position square cutouts over holes. Slide the two carriage bolts through the bracket and roof.

Place another assembled bracket onto the carriage bolts from the underside of roof as shown above and secure the mounting brackets to the roof with nuts. **Note:** The washer side of the nut must be against the bracket.

Place the cap over the inside bracket and secure with 1/4-20 x 5/8" hex screw.

5. Foot Pad assembly

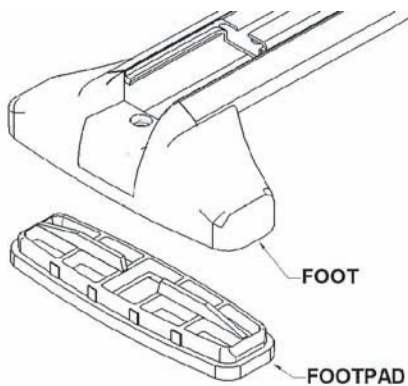

Snap the permanent mount footpads into each crossbar foot.

6. Mounting Crossbars onto Roof

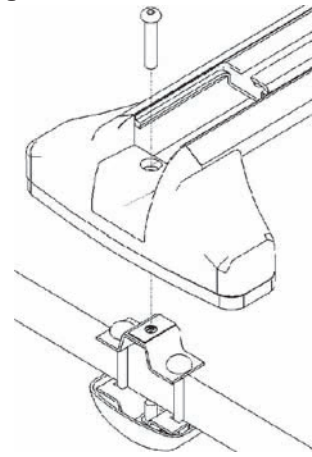

Remove the end caps by unscrewing the 1/4-20 x 9/16" narrow shoulder hex screw and sliding out from the end of the crossbar.

Place the crossbar feet over the assembled brackets.

Slide the 1/4-20 x 1-1/2" button head screw through the crossbar foot and into the U-clip.

Tighten the hex screw using the hex key.

7. Sliding End Caps on Crossbars

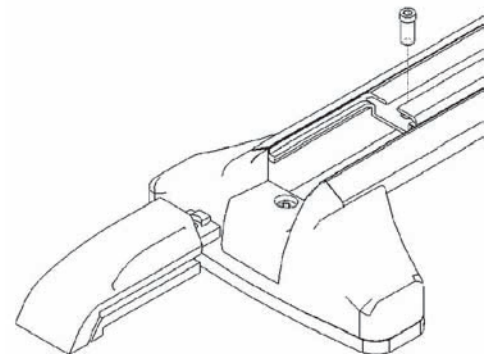

Slide the end caps into the crossbars and tighten the 1/4-20 X 9/16" narrow shoulder hex screws.

Place the hex key in vehicle glove box.

PRORAC GUIDELINES

Please review the instructions and warranty carefully. Assembly and installation are the purchaser's responsibility and beyond ProRac's control. Therefore, ProRac exclusively limits its warranty to the repair or replacement of a defective ProRac product for up to three years from retail purchase. Warranty excludes damage to your vehicle, cargo, or any person or property during assembly, installation, and use.

- * Do not carry more than 150 pounds (68KG) of combined cargo and accessories on ProRac crossbars. ProRac crossbars do not increase gutter or roof strength. ProRac cannot warranty loads that exceed this limit.
- * Do not use ProRac crossbars and accessories for purposes other than those for which they were designed. Do not exceed their carrying capacity. Failure to follow these guidelines or the product instructions will void the warranty.
- * Make sure all knobs, bolts, screws, straps, and locks are firmly attached, tightened, and locked before every trip. All fasteners must be periodically inspected for signs of wear, corrosion, and fatigue. Check your load at stops during long trips to ensure continued fastening security.
- * Check all local and state laws governing projection of objects beyond the width and length of vehicle. Be aware of the width and height of your cargo since low-clearance branches, bridges, and parking garages can affect the load. Never drive with any lock, knob, or rack in an open or unlocked position. All long loads such as, but not limited to, sailboards, surfboards, kayaks, canoes, and lumber must be tied down front and rear to the bumpers or tow hooks of the vehicle.
- * Remove your rack and accessories when they are not in use and before entering automatic car washes.
- * All locks must be turned and moved periodically to ensure smooth operation. Use graphite or similar dry lubricant. Locks are designed to deter vandalism and theft. Remove valuable gear if your vehicle is unattended. Replacement keys are available only through your ProRac dealer.
- * All cargo will affect the vehicle's driving behavior. For your safety, adapt your speed to the conditions of the road and load being carried. Obey all posted speed limits and traffic cautions.
- * Due to their wind resistance, do not carry disks or wheels with covers on the ProRac bike carrier.
- * Consult your ProRac dealer if you have questions regarding the operation and limits of ProRac products. Review all instructions and warranty information carefully.

