

Work Rack Installation Instructions 54" and 72" Load Bars

Package Contents:

- | | |
|---|--------------------------|
| (2) 54" or 72" Load Bar | (4) 1/4 Split Washers |
| (1) Lo Pro Track Kit | (12) Flanged Washers |
| (4) 1/4-20 X 2-1/4" Button Head Screws | (12) Cap Covers |
| (12) 1/4-20 X 1-1/2" Button Head Screws | (4) Feet |
| (4) End Caps | (6) Sliding Tie Downs |
| (1) Hex Wrench | (1) 3 oz tube Silicone |
| (4) U-Clips | (4) Sliding Rack Anchors |
| (12) 1/4-20 Nuts with Integral Lock Washers | |
| (4) 1/4-20 X 9/16" Narrow Shoulder Hex Screws | |



Photo shown with optional sliding load stops and 72" load bars.

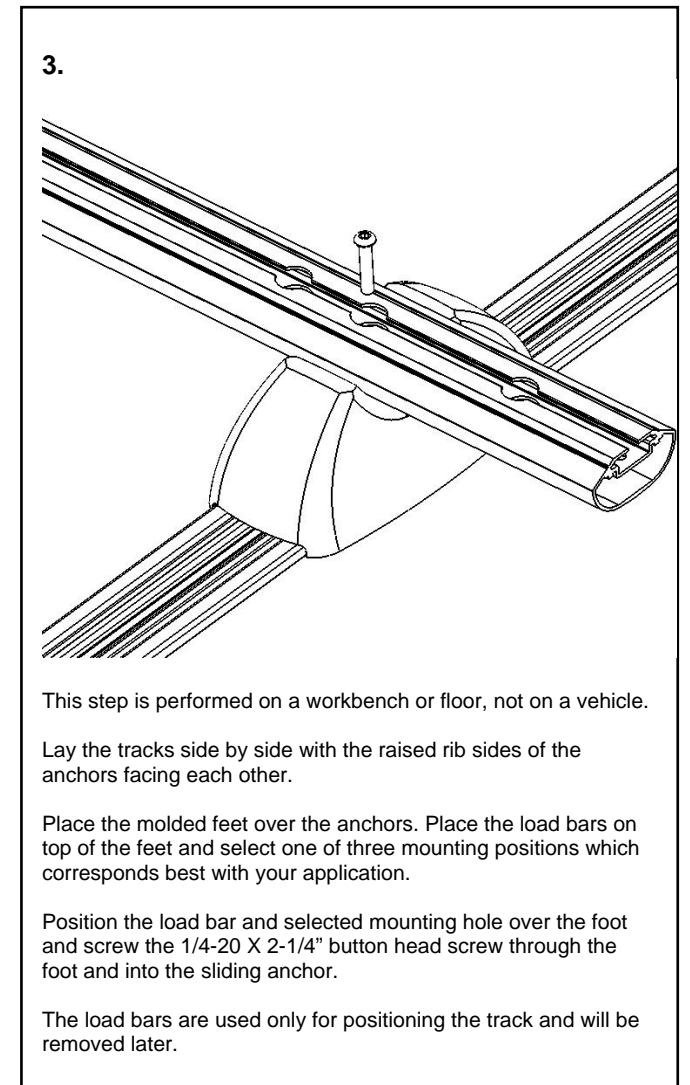
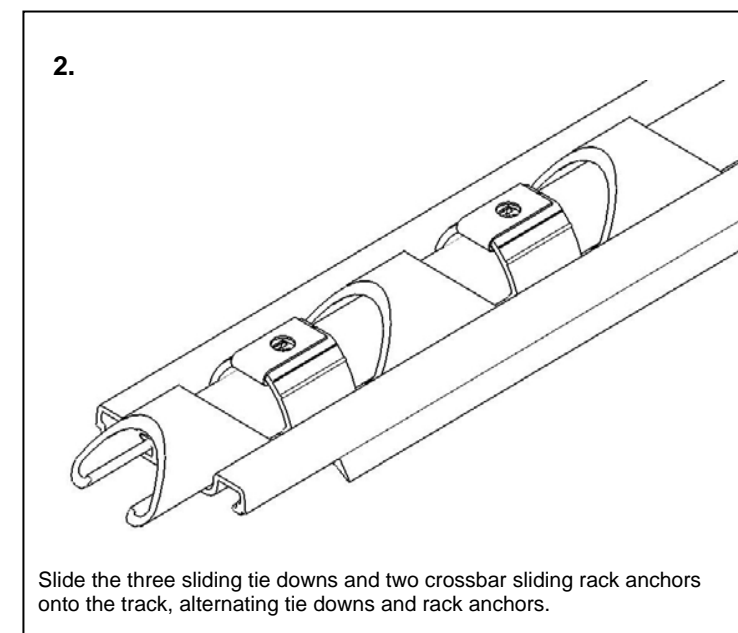
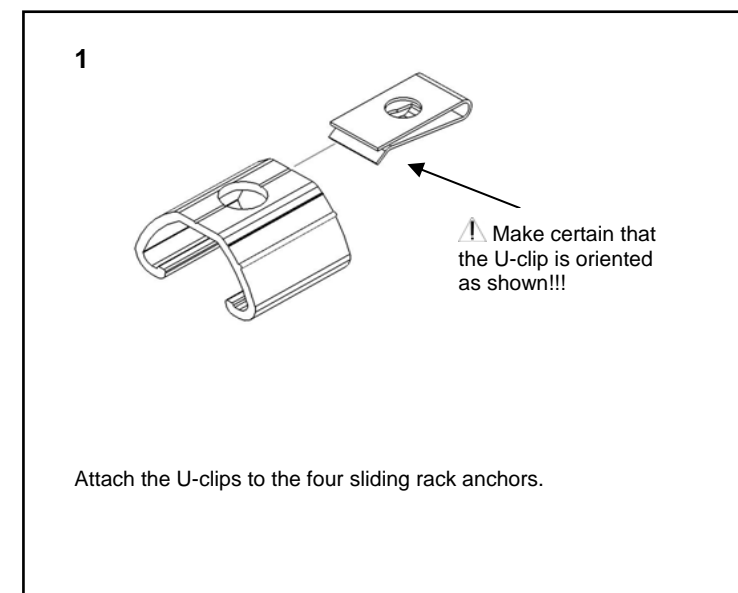

PRO RAC GUIDELINES

Please review the instructions and warranty carefully. Assembly and installation are the purchaser's responsibility and beyond ProRac's control. Therefore, ProRac exclusively limits its warranty to the repair or replacement of a defective ProRac product for up to three years from retail purchase. Warranty excludes damage to your vehicle, cargo, or any person or property during assembly, installation, and use.

- ◆ Do not carry more than 150 pounds (68KG) of combined cargo and accessories on ProRac load bars. ProRac load bars do not increase gutter or roof strength. ProRac cannot warranty loads that exceed this limit.
- ◆ Do not use ProRac load bars and accessories for purposes other than those for which they were designed. Do not exceed their carrying capacity. Failure to follow these guidelines or the product instructions will void the warranty.
- ◆ Make sure all knobs, bolts, screws, straps, and locks are firmly attached, tightened, and locked before every trip. All fasteners must be periodically inspected for signs of wear, corrosion, and fatigue. Check your load at stops during long trips to ensure continued fastening security.
- ◆ Check all local and state laws governing projection of objects beyond the width and length of vehicle. Be aware of the width and height of your cargo since low-clearance branches, bridges, and parking garages can affect the load. Never drive with any lock, knob, or rack in an open or unlocked position. All long loads such as, but not limited to, sailboards, surfboards, kayaks, canoes, and lumber must be tied down front and rear to the bumpers or tow hooks of the vehicle.
- ◆ Remove your rack and accessories when they are not in use and before entering automatic car washes.
- ◆ All locks must be turned and moved periodically to ensure smooth operation. Use graphite or similar dry lubricant. Locks are designed to deter vandalism and theft. Remove valuable gear if your vehicle is unattended. Replacement keys are available only through your ProRac dealer.
- ◆ All cargo will affect the vehicle's driving behavior. For your safety, adapt your speed to the conditions of the road and load being carried. Obey all posted speed limits and traffic cautions.
- ◆ Due to their wind resistance, do not carry disks or wheels with covers on the ProRac bike carrier.
- ◆ Consult your ProRac dealer if you have questions regarding the operation and limits of ProRac products. Review all instructions and warranty information carefully.

4.

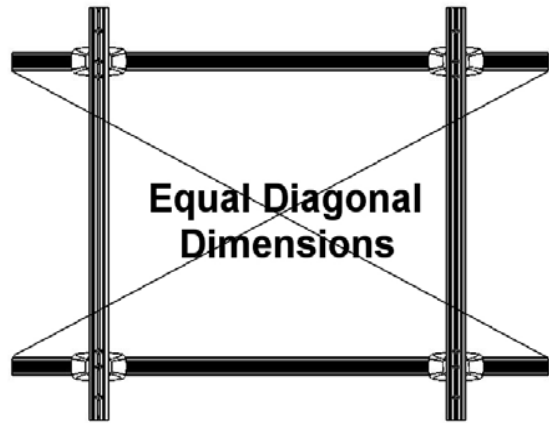

Ensure that the assembly is square by taking diagonal measurements from corner to corner.

When the measurements are equal, fully tighten the load bars to the tracks.

Place the assembly on the truck cap or tonneau cover and position using suggested dimensions in step 5.

5.

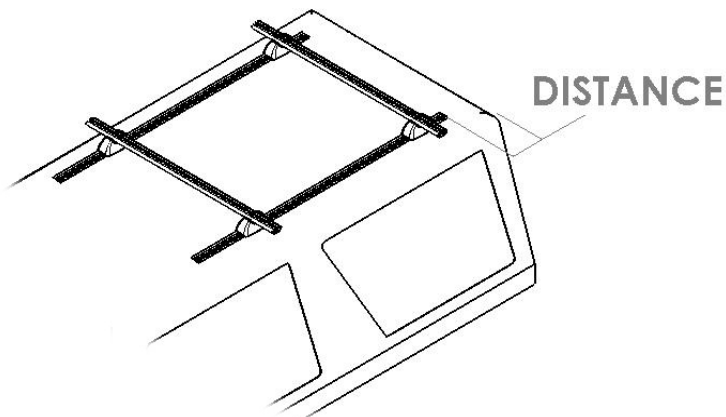

Inspect underneath cap or tonneau to avoid obstacles during assembly.

Suggested distance from rear of vehicle to tracks is 8" – 10" or centered as desired.

6.

Lift up the edges of the top gasket to reveal the corner holes.

Mark the center of the four corner holes using a center punch.

Remove assembly from the roof.

Remove crossbars from tracks.

7.

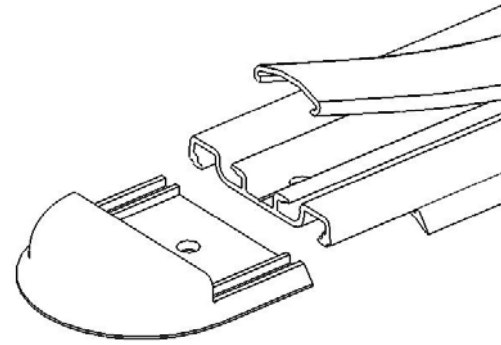

Center the bottom gasket on each track by sliding the end caps into the ends of the track.

8.

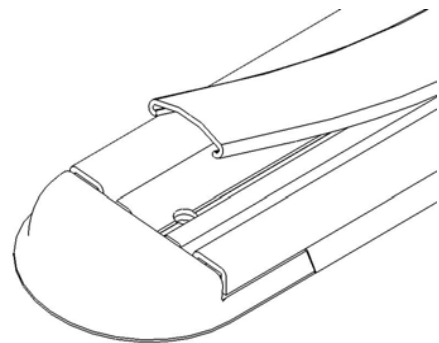

Temporarily secure the end caps to the track with tape. Lift the edges of the top gasket enough to reveal both corner holes.

Reposition the track on the roof, centering the center punch marks with the corner holes.

9.

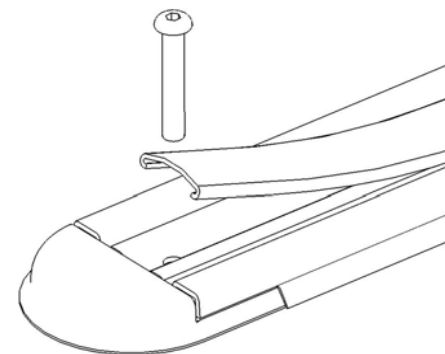

Using the corner hole as a guide, drill a ¼" diameter hole through the roof. Slide the ¼-20 x 1-½" screw through the hole.

Recheck the position of the other corner hole over the center punch mark. Reposition if needed.

Using the other corner hole as a guide, drill a ¼" diameter hole through the roof and place the ¼-20 x 1-½" screw through.

10.

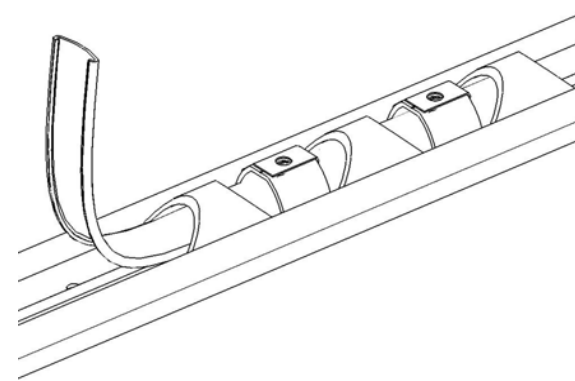

To gain access to the mounting holes:

Slide the rack anchors and tie downs together.

Lift the top cover gasket on one end and note the mounting hole near the rack anchors and tie downs.

Adjust the rack anchor and tie downs so they are near to the mounting hole.

Lift up the other end of the top cover gasket until it meets the tie down. This should give access to all mounting holes on the track.

Using the remaining mounting holes as guides, drill ¼" diameter holes through the roof.

Repeat for other track.

11.

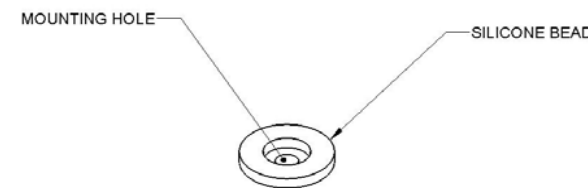

Remove the tracks from the roof.

Clean any debris from drilling the holes.

Place a bead of silicone around each hole on the cap / tonneau.

A bead of 1 inch in diameter (25mm), 1/8" (3mm) in height and ¼" (6mm) in width should be sufficient to seal the holes.

12.

Place two ¼-20 x 1-½" screws through the corner ends of the track.

Using the two screws as guides, position the track with the temporarily secured end caps over mounting holes.

Place the track onto the roof.

13.

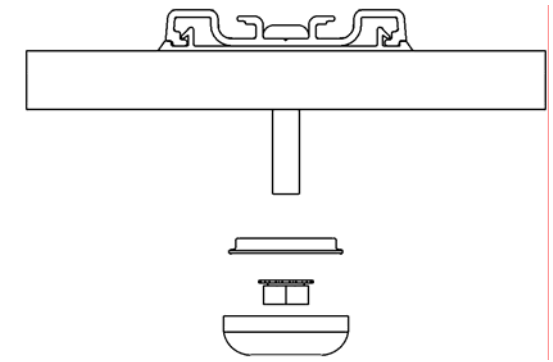

Place the remaining ¼-20 x 1-½" screws through the mounting holes and into the roof.

Secure track to roof by tightening the screws with flanged washers and nuts with integral lock washers.

Note the integral lock washer faces the flanged washer!

14.

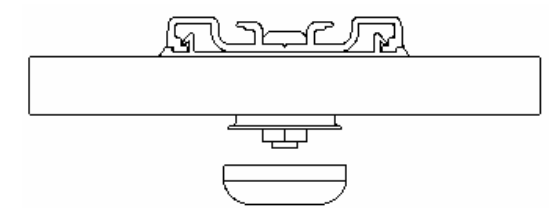

If necessary, cut screw to allow cap to fit properly on flanged washer.

Press caps onto the flanged washers.

Repeat steps 12 -14 for other track.

15.

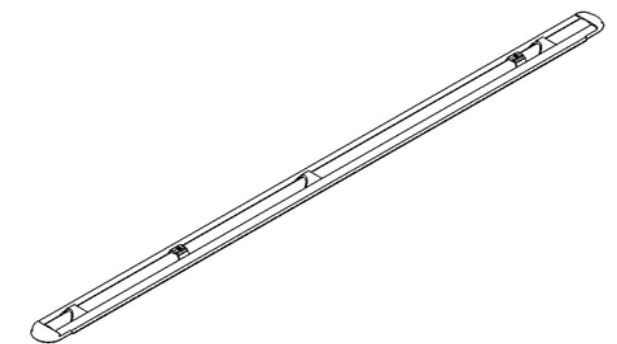

Remove the tape securing the end caps to the track.

Snap the top cover gasket into place.

Adjust the sliding rack anchors and tie downs to desired locations. Repeat for other track.

Place the cross bars over the rack anchors.