

PRO FLAPS

#101

DODGE INSTALLATION FOR FRONT

VEHICLE APPLICATION YEARS:
DODGE FRONT:
1994-CURRENT

1. Your PRO-FLAPS are designated left (driver's side) and right (passenger side). There is a 5/8" solid bar down the outside edge of the flap material.

2. Position your PRO-FLAPS at desired height. (bottom of flap to road surface is 7").
TIP: Use standard 7" coffee can to set height & level.

3. Mark and drill 1/4" hole in back edge of fender- Secure Flap using and secure the flap to the fender using 1/4x7/8" bolts and Nylock Nuts.

4. Align support bracket to flap attach to under fender. Attach other end of bracket to Pro Flap using nut and bolts.

(PRO-FLAPS) must have a minimum clearance from tires and exhaust pipes of 4 inches, on diesel engines, tail pipe must be 7", Damage to flap will occur if closer!
TIP: Any muffler shop can easily heat and bend exhaust pipe.

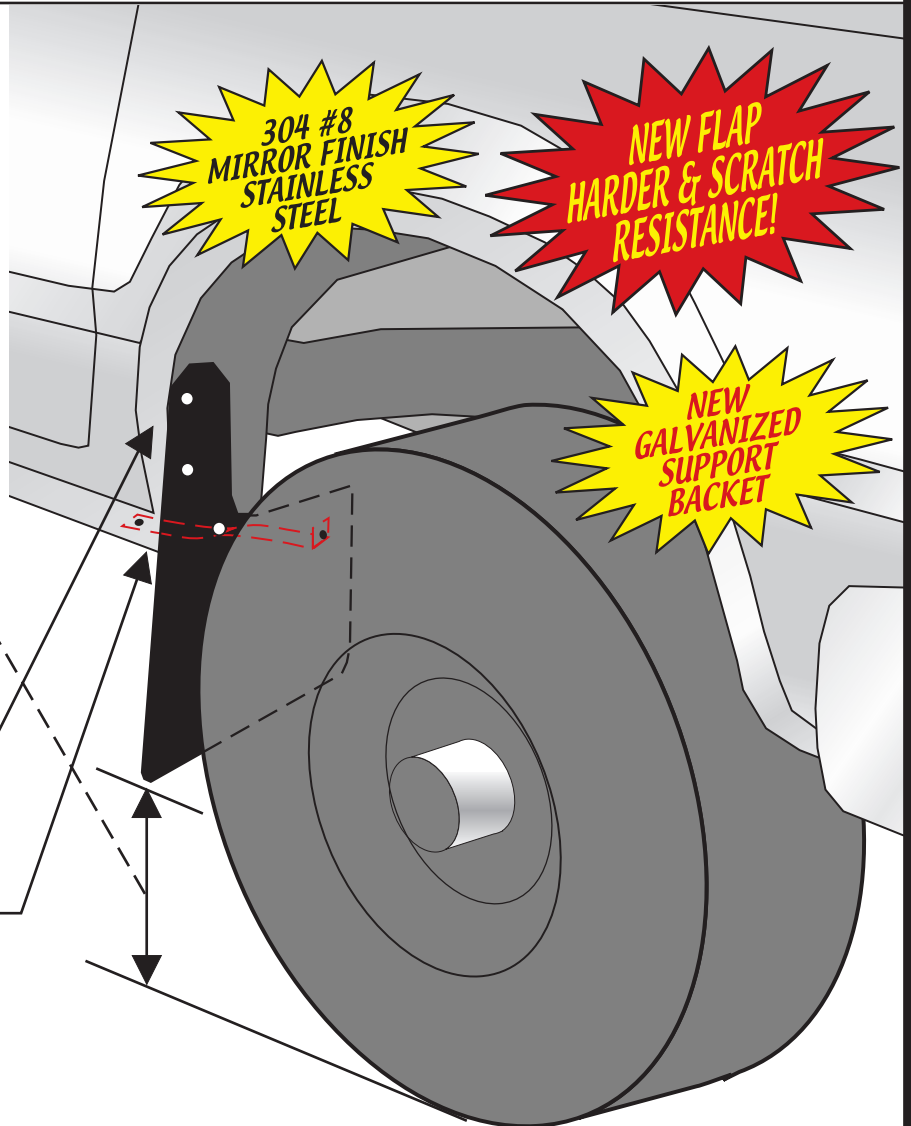

The feature that make PRO-FLAPS a NEW and exciting product line is the quality that is built into the Flap from the HEAVY DUTY 3/8 BLACK POLYURETHANE (no regrind) Anti-Spray Design, Groved on the tire side to Direct the Spray down, not out!

INSTALLATION:PARTS INCLUDED:

1. 10 - 1/4x7/8" Bolts
2. 20- 1/4 flat washers
3. Two support brackets
4. 10- Nylock Nuts
5. One set of PRO-FLAPS

TOOLS REQUIRED:

- A. (2) 7/16 End wrenches
- B. Drill motor
- C. 1/4" drill bit

Contact your F.R.U./PRO FLAPS Dealer
Or F.R.U. at 260 E. Pomona Rd., Yakima, WA 98901
Phone: (509) 453-4318 • Fax: (509) 249-8570

©2004 FRU All right reserved.