

ASSEMBLY INSTRUCTIONS

for :

# PRO-III

# KARGO MASTER<sup>®</sup>

(916) 638-8703

(800) 343-7486

• 11253- G Trade Center Drive • Rancho Cordova, CA 95742 •

**DON'T OVERLOAD YOUR VEHICLE!**

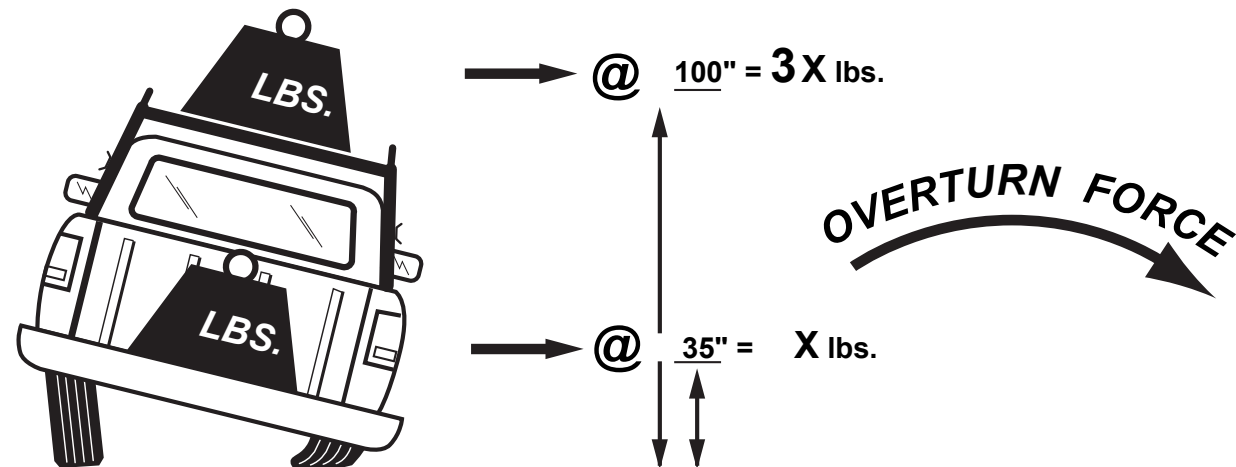

WEIGHT CARRIED ABOVE THE FLOOR OF THE TRUCK BED (E.G. ON AN OVERHEAD TRUCK RACK) WILL SIGNIFICANTLY INCREASE THE VEHICLE'S TENDENCY TO OVERTURN. ALWAYS KEEP HEAVY LOADS EVENLY DISTRIBUTED AND AS LOW AS POSSIBLE. IT IS IMPORTANT TO NOTE THAT THE KARGO MASTER RACK LOAD BEARING CAPACITY OF 1700 LBS. MAY BE GREATER THAN YOUR TRUCK'S GAWR OR GVWR CAPACITY, AND IS PROBABLY GREATER THAN THE WEIGHT THAT CAN BE SAFELY CARRIED OVERHEAD.

For TECHNICAL SUPPORT Call:

**1.800.343.7486**

HOURS: Monday- Friday 8:00 A.M. to 4:30 P.M. ( PACIFIC )

### ASSEMBLY INSTRUCTIONS

Read all instructions carefully and follow each step in proper sequence for ease and speed in assembling your **KARGO-MASTER RACK**. See below for nuts and bolts diagram.

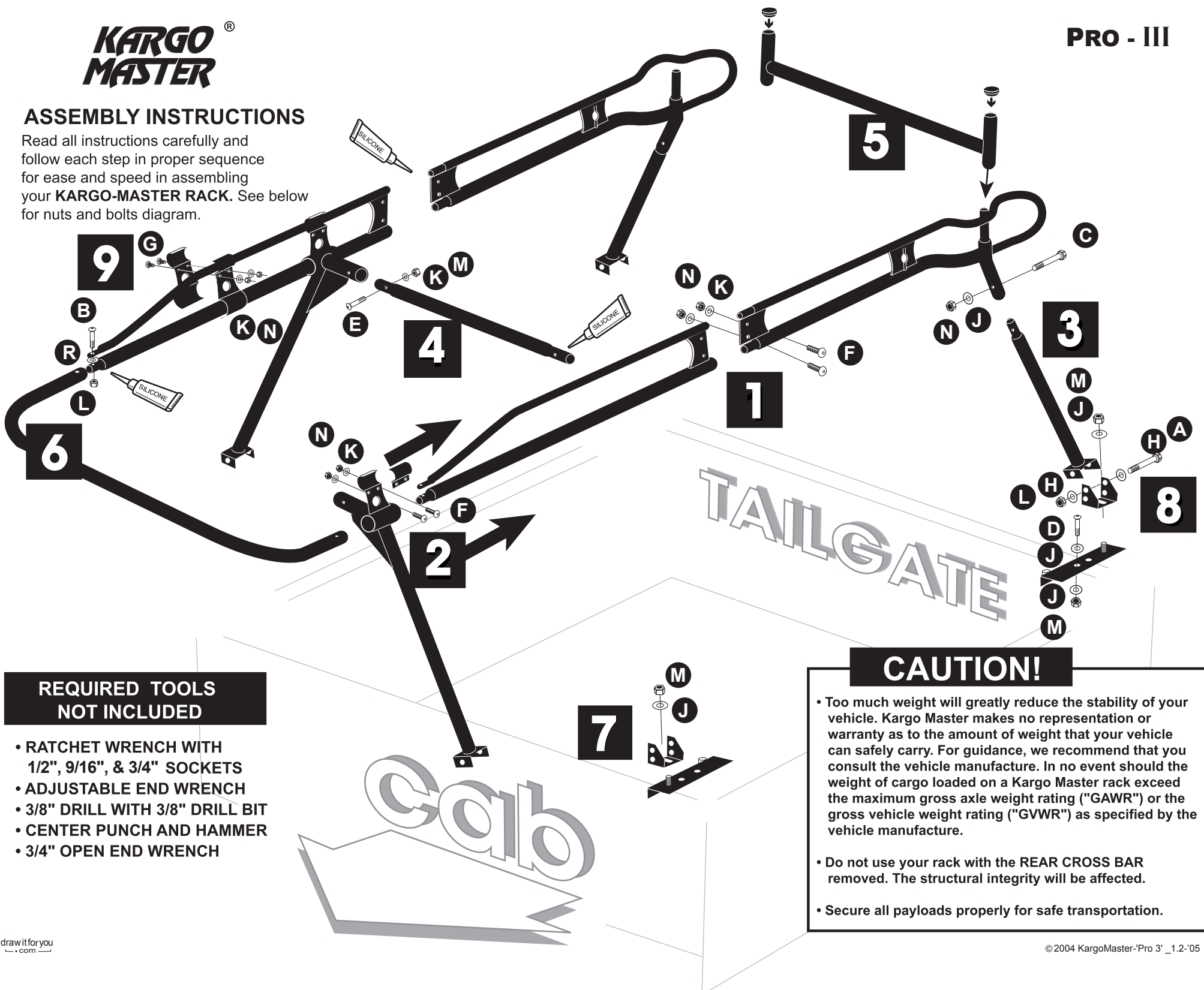

#### REQUIRED TOOLS NOT INCLUDED

- RATCHET WRENCH WITH 1/2", 9/16", & 3/4" SOCKETS
- ADJUSTABLE END WRENCH
- 3/8" DRILL WITH 3/8" DRILL BIT
- CENTER PUNCH AND HAMMER
- 3/4" OPEN END WRENCH

#### CAUTION!

- Too much weight will greatly reduce the stability of your vehicle. Kargo Master makes no representation or warranty as to the amount of weight that your vehicle can safely carry. For guidance, we recommend that you consult the vehicle manufacture. In no event should the weight of cargo loaded on a Kargo Master rack exceed the maximum gross axle weight rating ("GAWR") or the gross vehicle weight rating ("GVWR") as specified by the vehicle manufacture.
- Do not use your rack with the REAR CROSS BAR removed. The structural integrity will be affected.
- Secure all payloads properly for safe transportation.

**A (4 ea.)**  
1/2" x 3 1/2"  
Hex Bolt



**B (2 ea.)**  
1/2" x 2 1/4"  
Button Head Bolt



**C (2 ea.)**  
3/8" x 2"  
Button Head



**D (8 ea.)**  
3/8" x 1 3/4"  
Button Head



**E (2 ea.)**  
5/16" x 2"  
Button Head Bolt



**F (4 ea.)**  
5/16" x 3/4"  
Button Head Bolt



**G (4 ea.)**  
5/16" x 3/4"  
Carriage Bolt



**P (4 ea.)**  
5/16" x 3/8"  
Allen Head Set Screw



**S (4 ea.)**  
1/2" Spacer



**R (2 ea.)** 1/2" Rubber Washer



**L (6 ea.)**  
1/2" Jam Nut



**M (14 ea.)**  
3/8" Lock Nut



**N (14 ea.)**  
5/16" Lock Nut



**H (14 ea.)** 1/2" SAE Flat Washer



**J (22 ea.)** 3/8" SAE Flat Washer



**K (14 ea.)** 5/16" Flat Washer



## STEP 1

#1 = Cover entire swedge joints with silicone sealant and join FRONT and REAR side channels together, there is a LEFT & RIGHT FRONT, with the Right marked with a GREEN dot on the overlapping plate. There is a RIGHT & LEFT REAR. The leg cups angle outward. Be sure the connecting plates overlap, and bolt together with bolts **G**, washers **K** and lock nuts **N**.

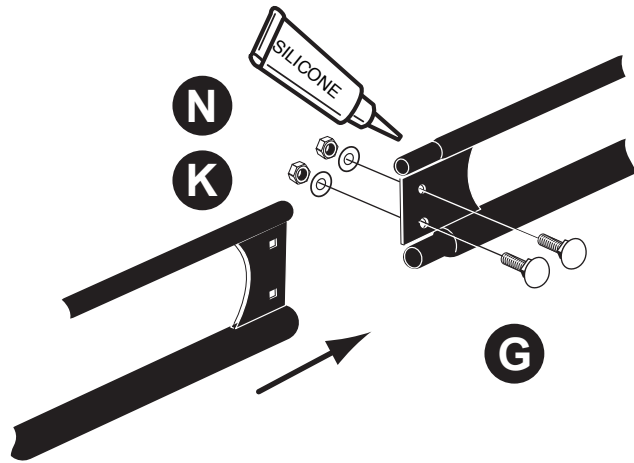

## STEP 2

#1 = Slide the FRONT leg onto the front side channel. There is a RIGHT & a LEFT. Match to the correct side channel so that both FRONT & REAR legs angle outward. Insert the set screws **P**, but do not tighten yet.

#2 = Loosely attach the top CLAMP with bolts **F**, washers **K**, and nuts **N**.

#3 = Final positioning of the front legs will follow in STEP 7.

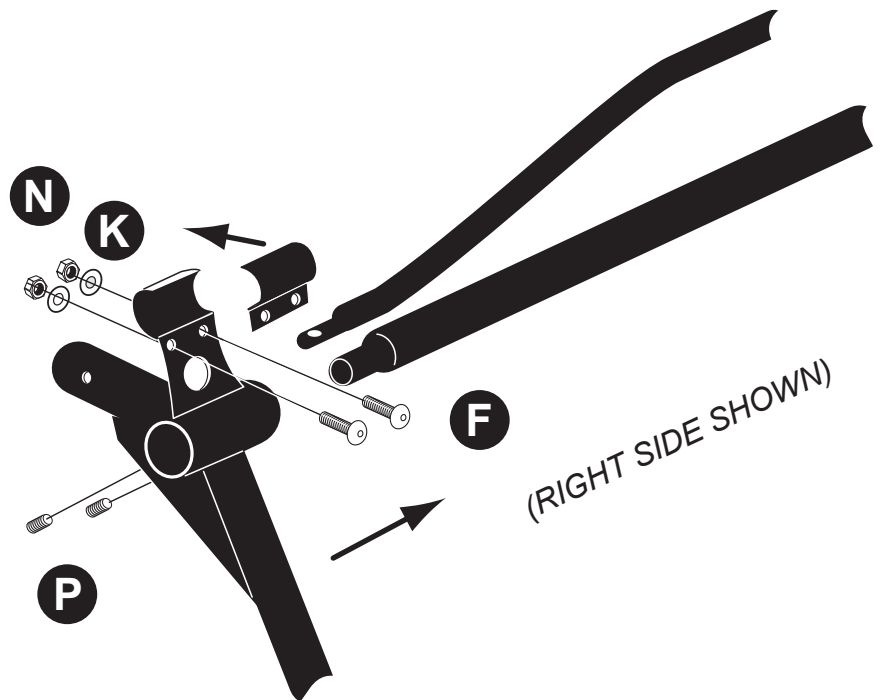

## STEP 3

#1 = Cover entire swedge joints with silicone sealant and attach the REAR LEGS with bolts **C**, washers **J**, and nuts **M**.

**Note:** The distance between front & rear legs will not be longer than the inside measurements of the bed itself.

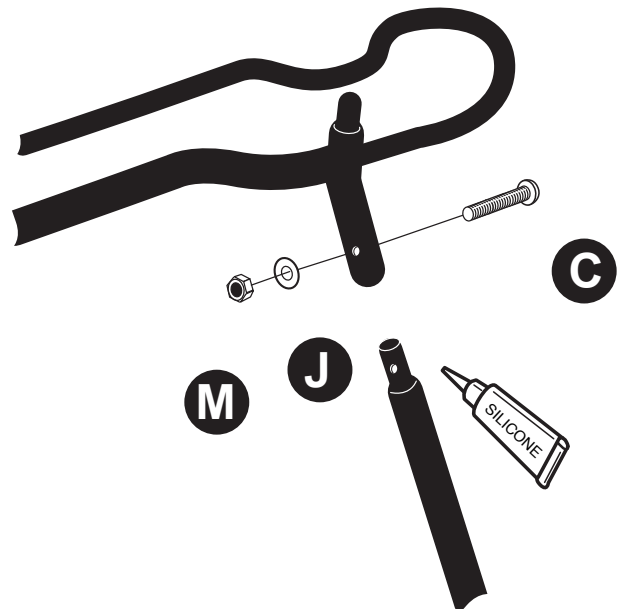

## STEP 4

#1 = Cover entire swedge joints with silicone sealant and insert the CENTER CROSS BAR into the SIDE RAIL CUPS and attach with bolts **E**, washers **K** and lock nuts **N**.

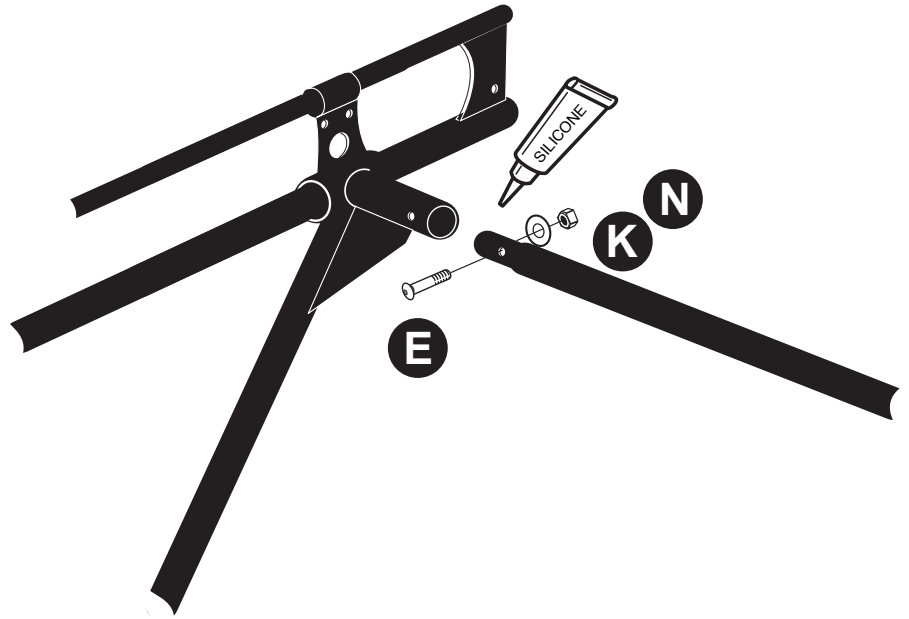

## STEP 5

#1 = Insert PLASTIC CAPS onto the rear crossbar uprights, (the tall side of the tube). Slide the REAR CROSS BAR into the REAR LEG POSTS at the top, as shown.

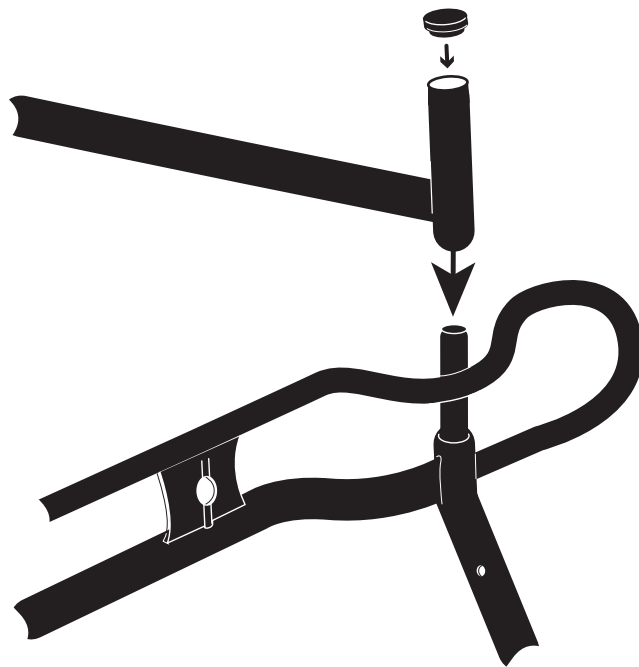

## STEP 6

#1 = Cover entire swedge joints with silicone sealant and slide FRONT CROSS BAR onto side rails and bolt together with bolts **B**, rubber washer **R**, and jam nut **L**.

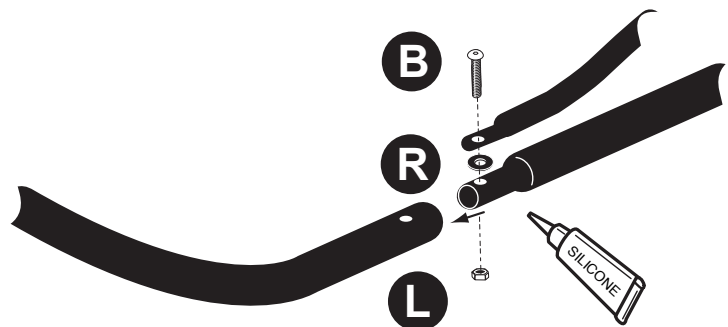

# STEP 7

**#1 = Be sure MOUNTING PLATES are as far forward towards the cab as possible, and as far back as possible for rear mounts, as shown.** Find the pre-drilled hole in the footplate that is furthest from the leg and drill 3/8" hole through truck's bed rail. You must drill a second bolt hole through both the footplate and the truck's bed rail. Locate this second hole as close as possible to the front leg, but making sure you can access the end of the bolt underneath the truck's bed rail as necessary to put on the washer and nut. Attach the footplate to the truck using bolts **D**, washers **J** and nuts **M**.

**#2 =** Repeat above instructions for the FRONT MOUNT PLATES by positioning FRONT FOOT PLATES as far forward towards the cab as possible on the truck bed rail. (When using the optional CLAMP ON KIT, position pre-drilled hole in the foot plate over stake pocket). Attach by drilling through bed rail and bolt on using bolts **D**, washers **J**, and nuts **M**.

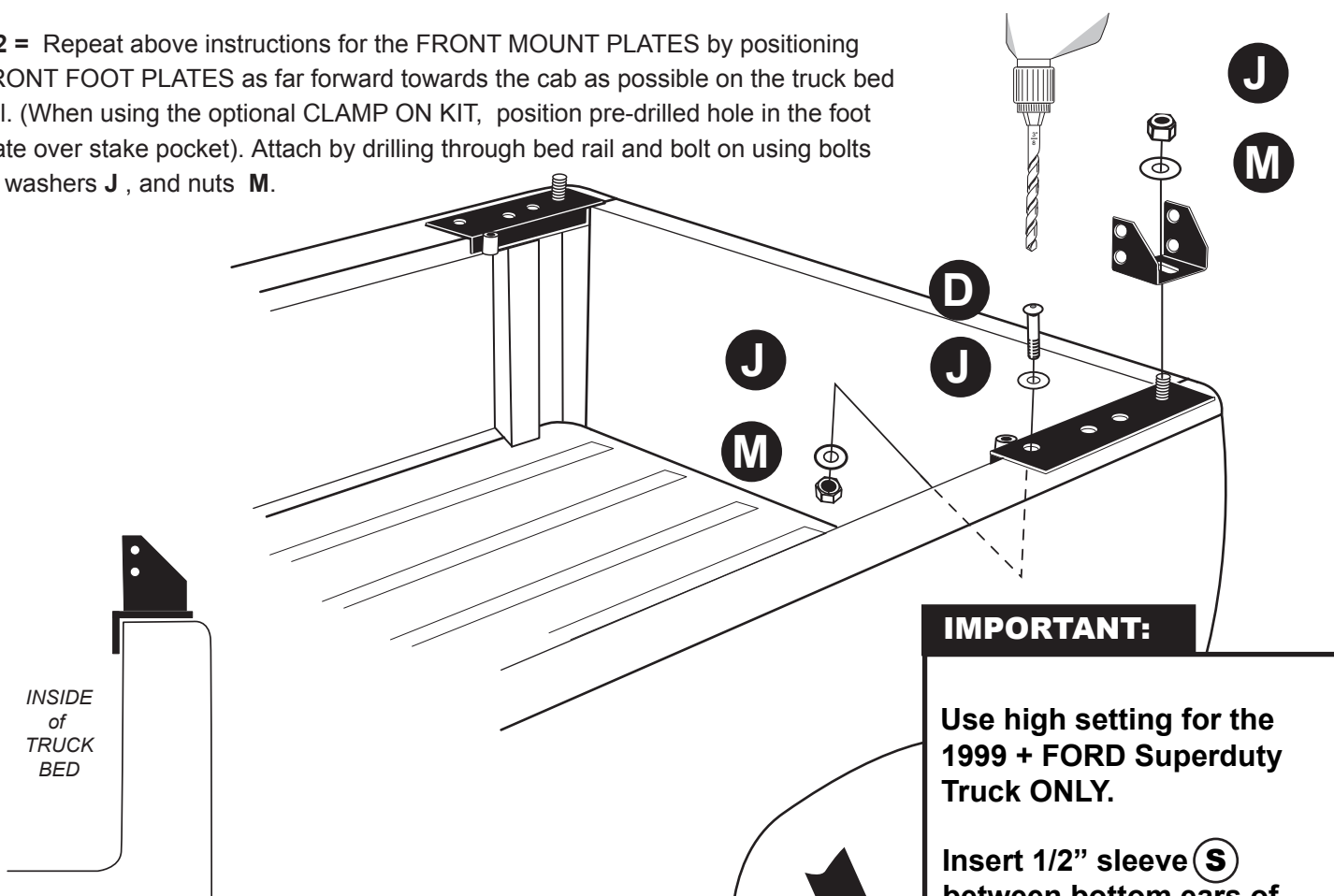

**#3 =** Attach the U-BRACKETS onto the FOOT PLATES loosely with washers **J**, and nut **M**. **Be sure to orient U-BRACKETS so that the holes are on the inside of the truck bed, as shown.**

Next, measure the distance, C/L to C/L, between the FRONT and REAR U-BRACKETS. Adjust the distance between the FRONT and REAR LEGS to match. Then set the rack on the truck and attach the legs with bolts **A**, washers **H**, and nuts **L**.

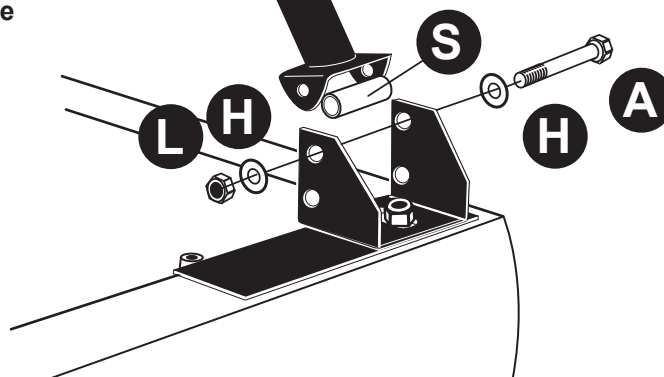

**STEP 8**

#1 = Attach front leg with bolts **A**, washers **H**, and nut **L**.

Center rack on truck bed.

Tighten up the bolts on the crossbar and clamp plates as well as the set screws **P**.

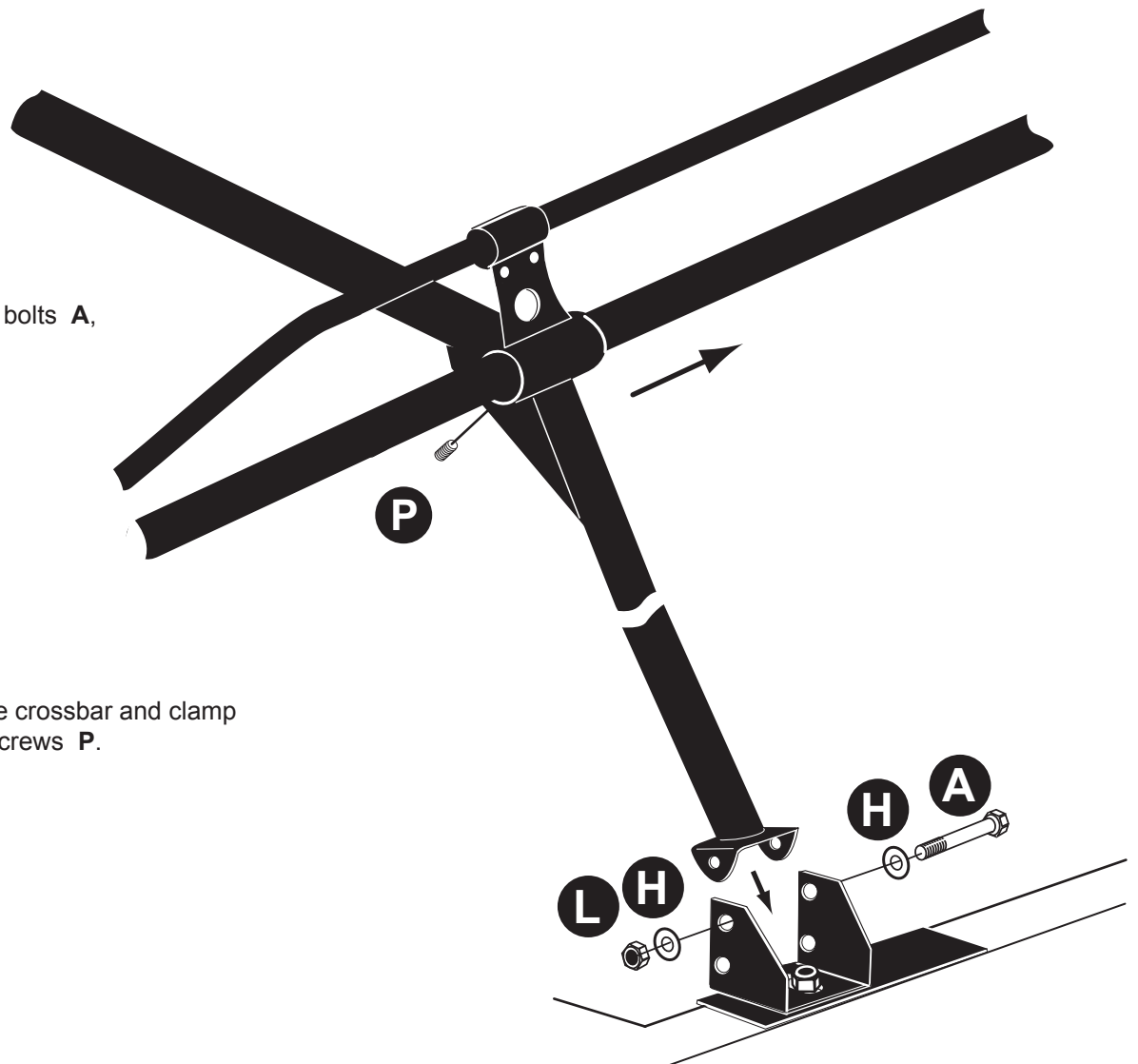
**STEP 9**

#1 = Attach the front SUPPORT UPRIGHT where the 1" tube begins to bend downward, then...

**TIGHTEN DOWN EVERYTHING AND....**

**THAT'S IT!**

*You're ready to LOAD & GO!*

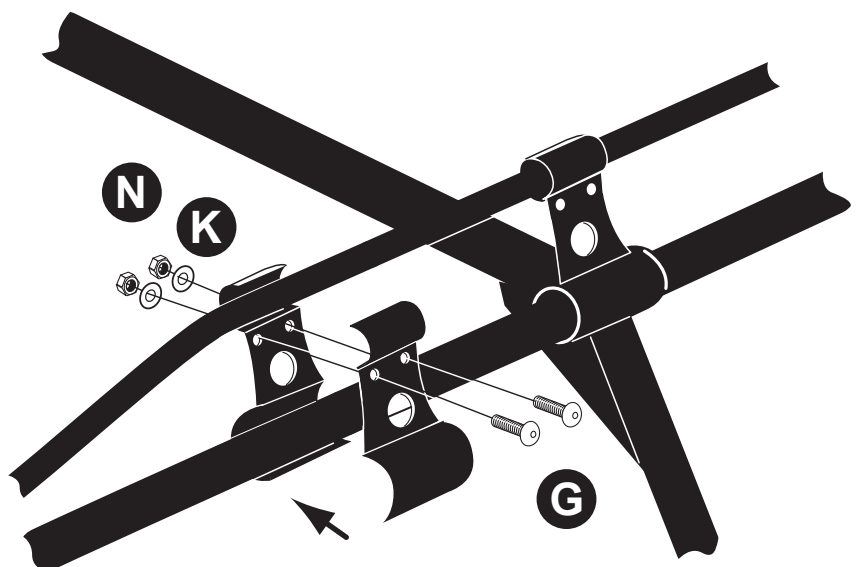

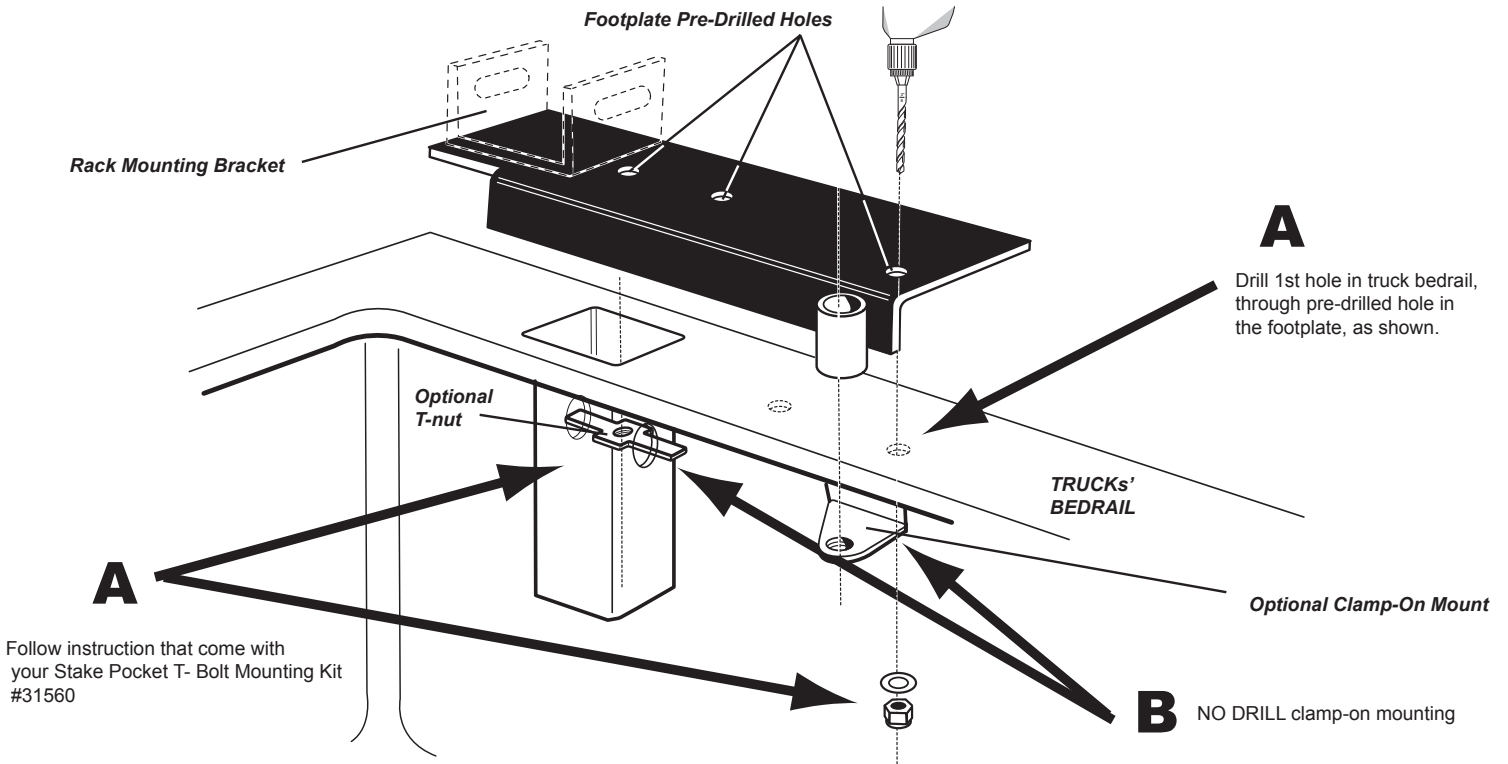

**OPTION A** PURCHASED SEPARATELY:

When it is not possible to locate a bolt close to the front leg, use our optional Stake Pocket T- Bolt Kit #31560. The T-nuts will go into the stake pocket to secure the footplate to bed rail, along with the hole drilled into the trucks' bed rail through the pre-drilled hole in the footplate. Complete instructions come with the kit.

**OPTION B** PURCHASED SEPARATELY:

This plan is the NO DRILL ANYTHING solution. These clamps allow you to bolt down the footplates to the trucks' bed rail without having to drill any holes in your truck or the footplate. This kit is #31580.

For TECHNICAL SUPPORT Call:

**1.800.343.7486**

HOURS: Monday- Friday 8:00 A.M. to 4:30 P.M. (PACIFIC)

**NOTES:**