

TracVan

The Ultimate Van Rack

Installation Manual

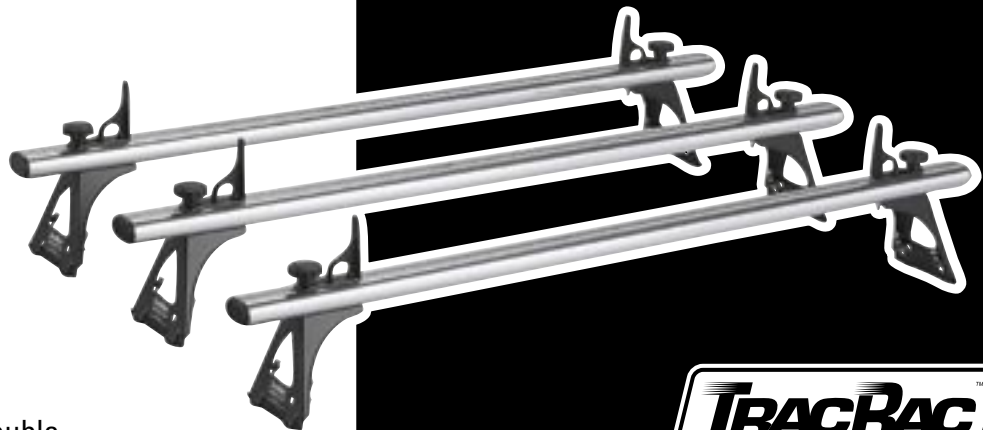

SKU# 29055 TracVan Double
SKU# 29056 TracVan Triple



Engineered to Deliver



TRACVAN INSTALLATION INSTRUCTIONS SKU# 29055 & 29056

TracVan installation is straightforward, and should take you under 20 minutes to complete. You'll attach the Crossbars to the Corner Brackets, then attach this assembly to the Gutter Rails of your van.

1. Verify that you have received the correct parts using the attached Assembly Drawing and Packing Checklist.

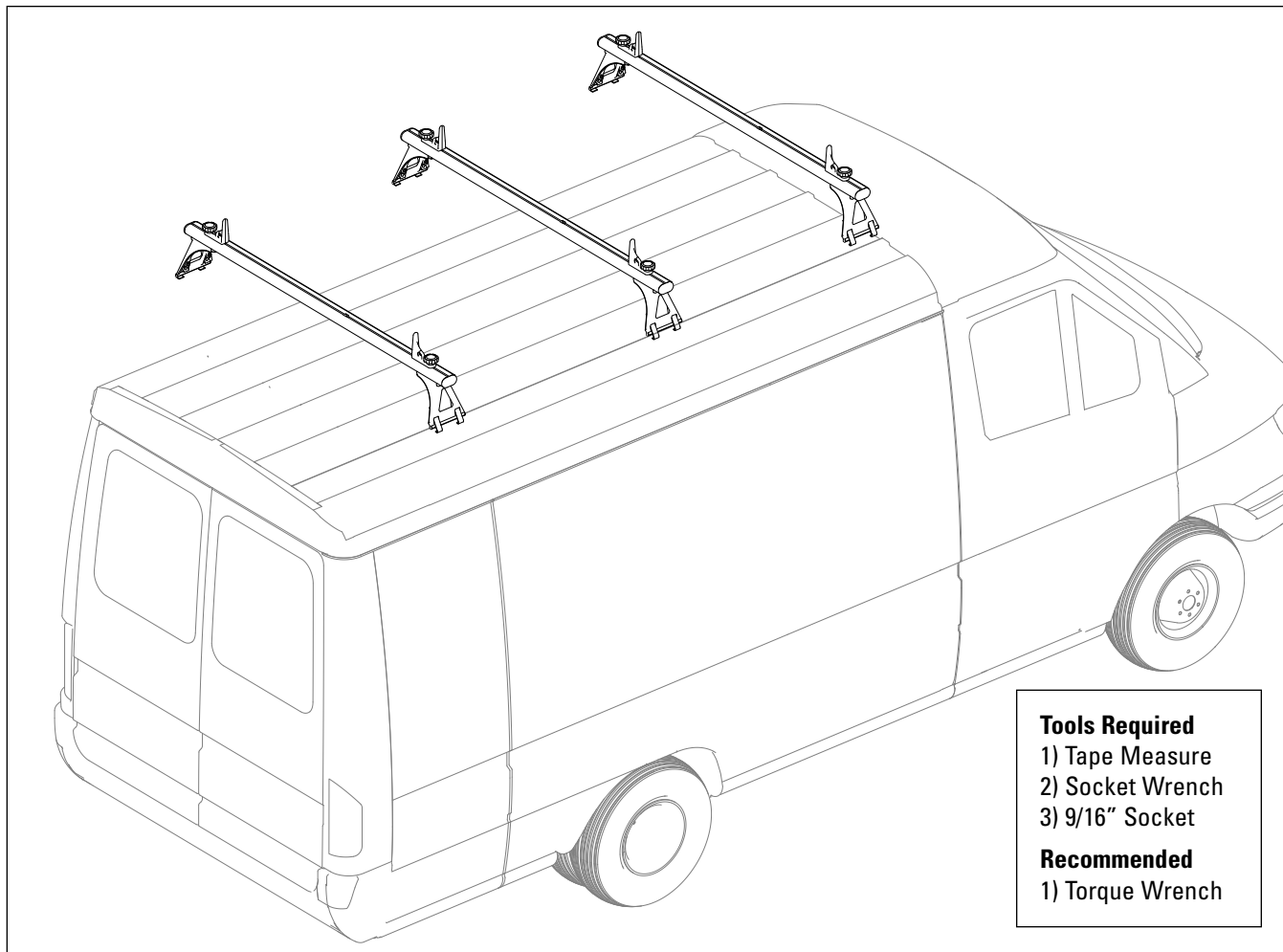

Tools Required

- 1) Tape Measure
- 2) Socket Wrench
- 3) 9/16" Socket

Recommended

- 1) Torque Wrench

Special Installation notes:

- All 1998+ Chevy Express / GMC Savanna (G-Series Vans) require the supplied Gutter Span, which are designed to span the putty filled rain gutter of the Van for maximum strength. If you use the supplied Gutter Spans, refer to "Roof Installation B" instructions on page 5 for proper installation.
- All 2000+ Ford Econoline Vans: DO NOT install the rubber strips to the Corner Brackets.
- When installing a TracVan Triple (SKU# 29056) to a Chevy Express / GMC Savanna (G-Series Vans) and Ford Vans with curved roofs you'll need to add the supplied Shims, to compensate for the gutter's curve.



Gutter Span



Shim

2. Fit the Rubber Strip on the lower edge of each Corner Bracket.

Do not install strip:

- On 2000+ Ford 150 Econoline vans.
- If using the Gutter Spans

3. Insert 2 (5/16" x 1 3/4" long) Socket Head Cap Screws through the Lock Washers and then into the holes in each Corner Bracket Tab. (See Fig. 1)

6. Attach a Corner Bracket assembly to the Crossbar by inserting the T-Bolts through the two holes in the Corner Bracket. Partially tighten and secure with the Self Locking Nuts – enough to hold the Corner Bracket in place. Repeat for each of the remaining three Brackets.

7. Slide the Crossbar Tiedowns onto the Crossbar by inserting the T-Bolts into the top Crossbar Slot.

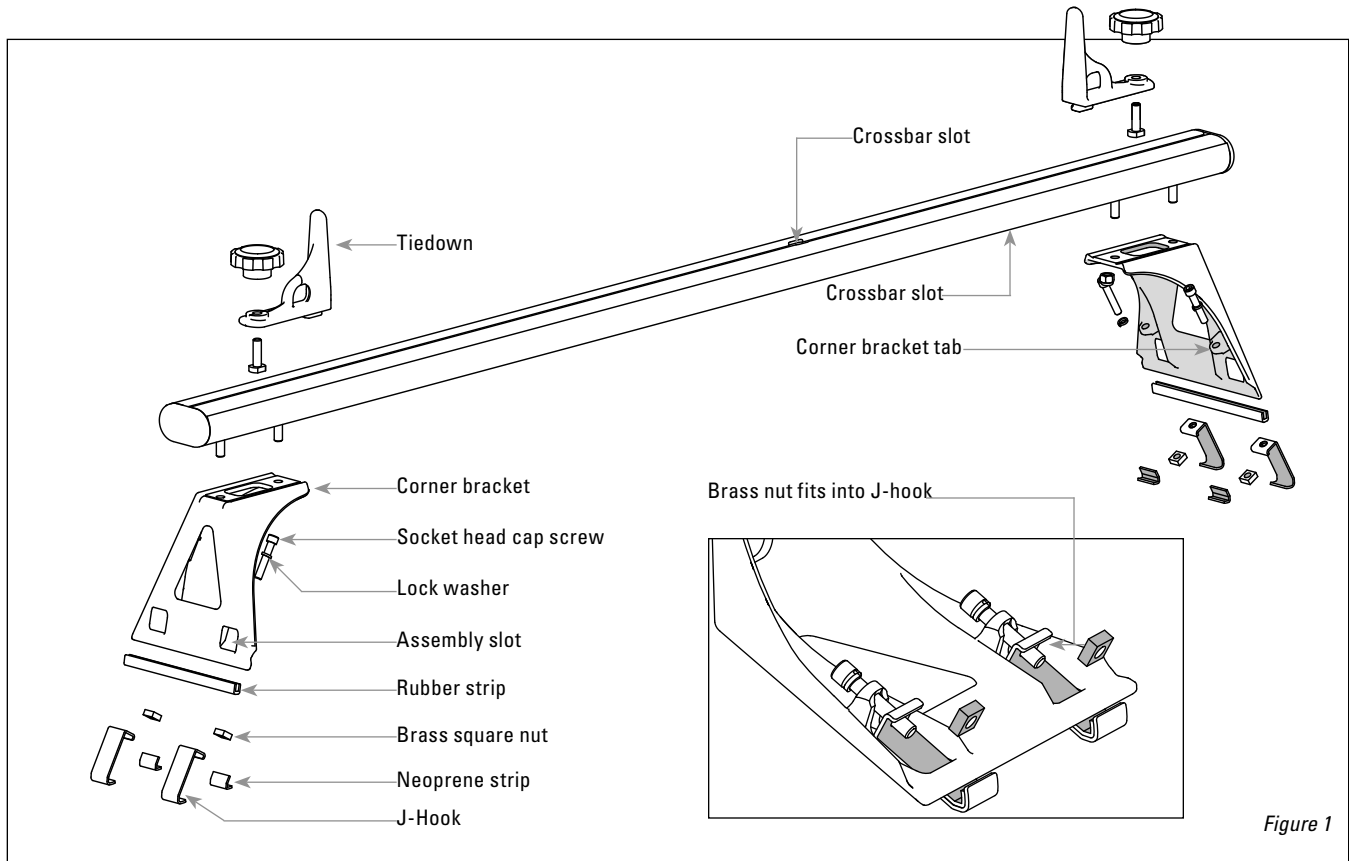

Figure 1

4. Insert the J-Hooks with Neoprene Strips through the Assembly Slots at the base of the Corner Bracket. Then insert 2 Brass Nuts into the opening of the J-Hook clips. Thread each screw approx. 1/4 in. into the J-hook's brass nut. (Do not completely tighten screws) Repeat for each Corner Bracket, (2 hooks for each Bracket). (See Fig. 1)

5. Now you're ready to attach the Crossbars (see Shim Installation, page 6, if shims are required on front and rear racks). Insert the heads of four 1 1/2" T-Bolts into the Crossbar Slot on the bottom of each Crossbar (the bottom is the side with the Flat Recess) (see Fig. 2). Slide 2 T-Bolts to the left side and 2 T-Bolts to the right.

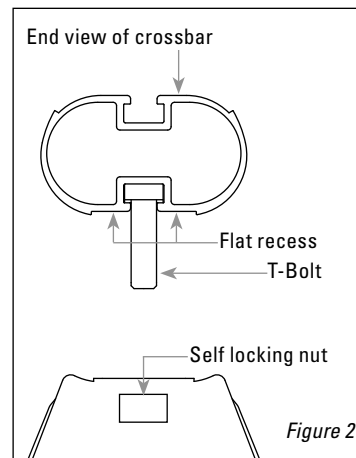

Figure 2

8. Place a complete assembly at the desired location on the van's roof, making sure that the Crossbars are parallel with the front of the van. Check that the Corner Brackets are the same distance from the driver and passenger doors.

- **Roof Installation A: Normal Installation**
- **Roof Installation B: Gutter Span Installation**

Roof Installation A: Normal Installation

9. The lower edge of each Corner Bracket fits snugly into the top corner of the van's rain gutter. Place the J-Hooks with Neoprene Strips around the outside edge of rain gutter (see Fig 3A).

CAUTION: Re-torque all fasteners after first 100 miles to adjust for settling. Recheck all torques every 3000 miles. Prolonged driving, vibrations may cause the fasteners to loosen.

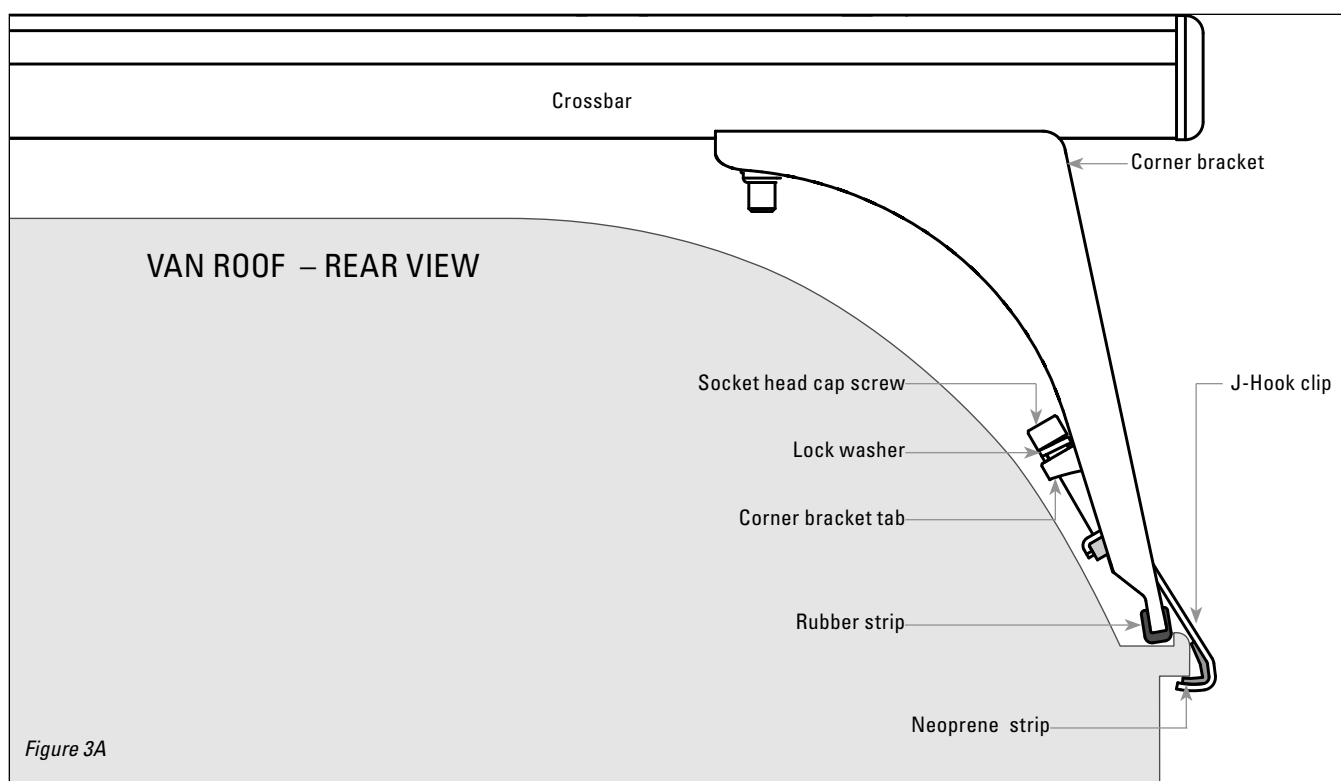

Figure 3A

10. Center the Crossbars by measuring from the end of each Corner Bracket, to the Crossbar ends, left and right.
11. Tighten the T-Bolts on the underside of the Crossbar to 240 in/lbs. (20 ft/lbs.) to secure the Corner Brackets to the Crossbar.
12. Now tighten all Socket Head Cap Screws to 120 in/lbs. (10 ft/lbs.) with the supplied Allen Wrench.
13. Reposition the Crossbar Tiedowns where desired. Now you're ready to go!

Capacity – The TracVan System is rated for a capacity of 500 lbs., evenly distributed over all racks, assuming normal driving conditions and loading.

Do not exceed the racks' rated capacity, as you could damage the van's rain gutter.

Secure loads carefully and exercise caution at all times.

- We recommend using transverse ratchet straps to securely tie down cargo.
- Run additional ratchet straps around the front & rear of loads, attaching them to the Crossbars to prevent any load shifting during acceleration and stopping.

Roof Installation B: Gutter Span Installation

9. Slide 2 Gutter Spans under each Corner Bracket so that they line up under the slots as shown, with the “V” Groove facing up. The “Hook” of the Gutter span must engage the upper edge of the gutter, with the opposite end positioned in the middle of the gutter groove (see Fig 3B).

CAUTION: Re-torque all fasteners after first 100 miles to adjust for settling. Recheck all torques every 3000 miles. Prolonged driving, vibrations may cause the fasteners to loosen.

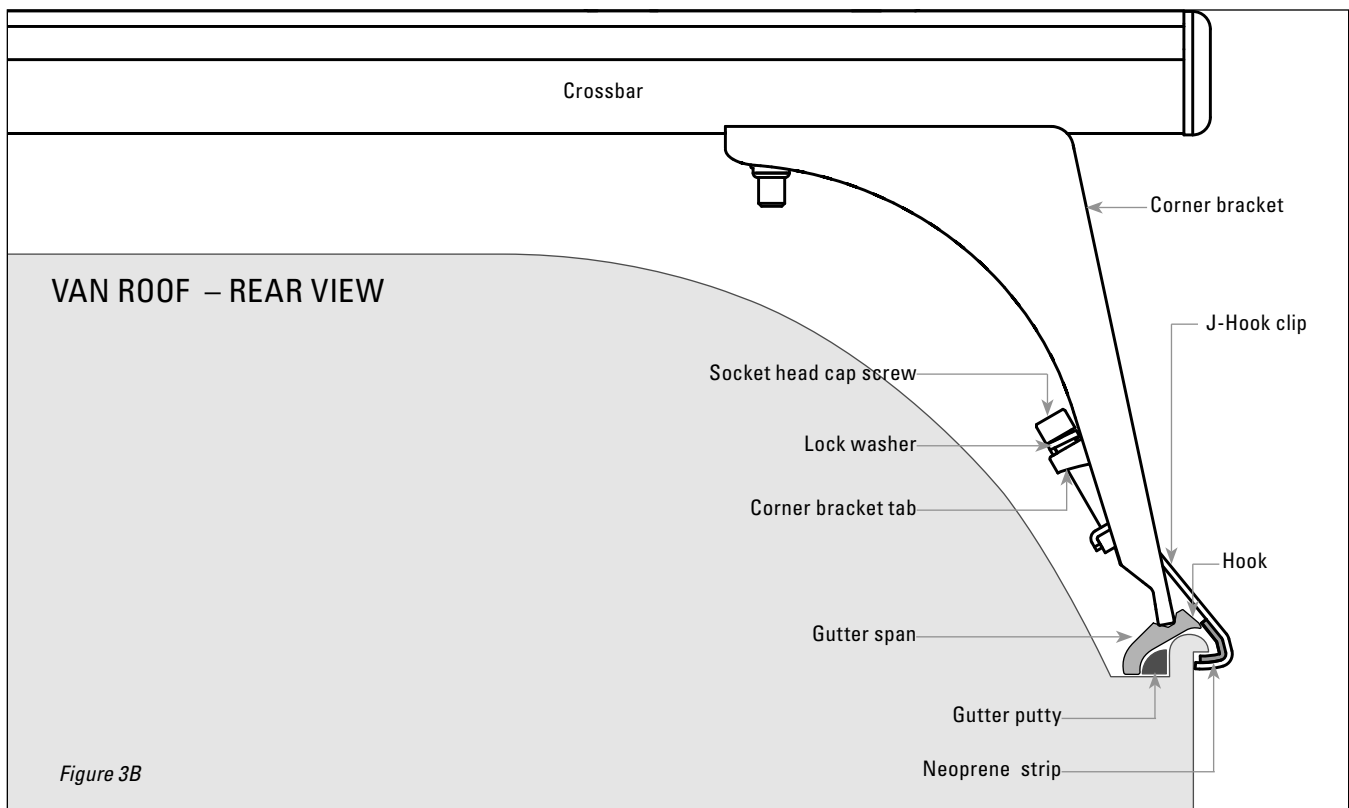

Figure 3B

10. The lower edge of each Corner Bracket fits snugly into the top of the Gutter Span. Place the J-Hooks around the outside edge of rain gutter (see Fig 3B).
11. Center the Crossbars by measuring from the end of each Corner Bracket, to the Crossbar ends, left and right.
12. Tighten the T-Bolts on the underside of the Crossbar to 240 in/lbs. (20 ft/lbs.) to secure the Corner Brackets to the Crossbar.
13. Now tighten all Socket Head Cap Screws to 120 in/lbs. (10 ft/lbs.) with the supplied Allen Wrench.
14. Reposition the Crossbar Tiedowns where desired.
Now you're ready to go!

Capacity – The TracVan System is rated for a capacity of 500 lbs., evenly distributed over all racks, assuming normal driving conditions and loading.

Do not exceed the racks' rated capacity, as you could damage the van's rain gutter.

Secure loads carefully and exercise caution at all times.

- We recommend using transverse ratchet straps to securely tie down cargo.
- Run additional ratchet straps around the front & rear of loads, attaching them to the Crossbars to prevent any load shifting during acceleration and stopping.



SHIM INSTALLATION

Supplied as part of SKU 29056, TracVan Triple

The gutters on some Vans are curved, which makes installing three level crossbars a special challenge. To compensate for this curvature, you'll install our shims in the front and rear crossbar assemblies, raising them to the height of the middle rack.

1. Verify that you have received four Van Rack Shims.
2. Install the middle (third) crossbar assembly roughly in center of van roof per Van Rack Installation Instructions.
3. Loosely assemble the front and rear crossbar assemblies, placing the shims between the corner brackets and the crossbar (*Fig. 4*).
4. Install the front crossbar assembly in desired location near front of van roof, and tighten all fasteners in accordance with Van Rack Installation Instructions.
5. Position the rear crossbar assembly on rear of van roof, engaging lower edge of corner brackets in rain gutters.
6. Place a straight-edge (a ladder or straight piece of lumber will do) atop crossbars (*Fig. 5*) to check that the racks are all in line. As necessary, slide the rear crossbar assembly to the front or rear until the straight-edge rests flatly and evenly on all three crossbars. Complete installation to rear crossbar assembly in accordance with Van Rack Installation Instructions.
7. Check all fasteners for proper torque.

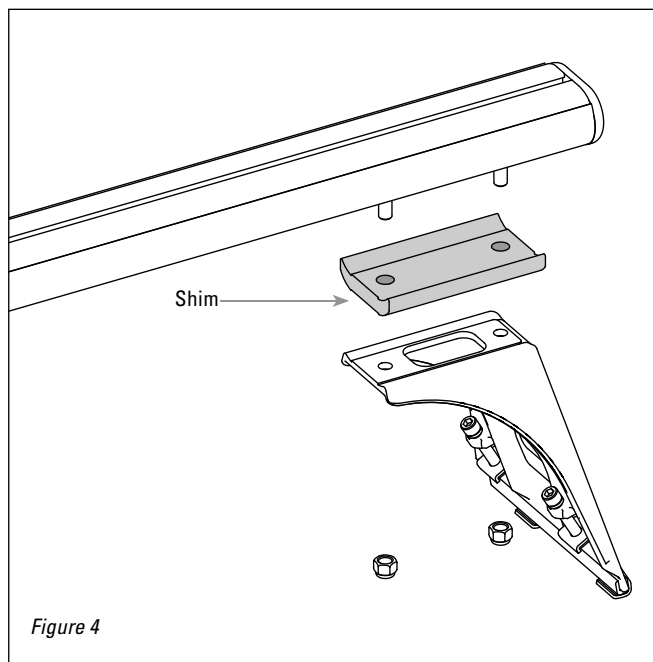

Figure 4

Caution: Recheck the bolt torques every 500 miles.

With prolonged driving, vibrations may cause the fasteners to loosen.

Capacity: The van rack is rated for a capacity of 500 lbs., evenly distributed, assuming normal driving conditions and loading. Please secure loads carefully, and exercise caution at all times!

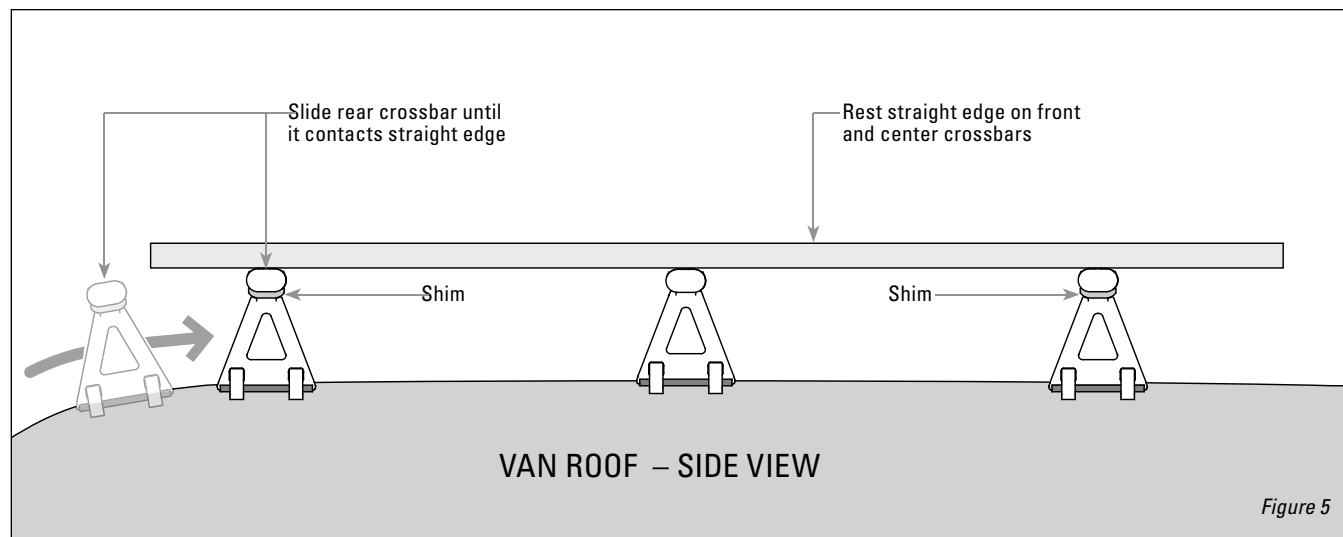

Figure 5