



FULL METAL

JACK RABBIT

RETRACTABLE HARD TONNEAU COVER



INSTALLATION INSTRUCTIONS



Pace Edwards Company
2400 Commercial Blvd.
Centralia WA 98531

(800) 338-3697 toll free
(360) 736-9991 main
(360) 736-9992 fax

www.paceedwards.com

Part #: FMJR-INSTALL 115
Revised 11/05

TABLE OF CONTENTS

Tools Required for Assembly	2
Before You Start	2
Drain Hole Locations (FIG. 1).....	2
STEP 1: Remove Plywood Packaging	2
Packaging Contents (FIG. 2)	2
STEP 2: Positioning Canister (FIG. 3)	3
STEP 2: Installing Rails (FIG. 4, 5 & 6).....	3
STEP 4: Repositioning Canister.....	4
STEP 5: Installing Clamps (FIG. 7, 8, 9 & 10).....	4
STEP 6: Lubricating & Placing Sweep Seals (FIG. 11).....	5
STEP 7: Installing Drain Tubes.....	5
STEP 8: Install Top Cover & Velcro (FIG. 12).....	5
Operating Instructions	6
Helpful Maintenance Hints	6

TOOLS REQUIRED FOR ASSEMBLY:

7/16" wrench or socket Tape measure
#2 Philips screwdriver Petroleum-based lubricant

Note: There should be no drilling into the truck body needed on most standard or full-size trucks .

BEFORE YOU START:

Read the instructions carefully before you start. These instructions are written for one-person installation. We have noted in a couple of places where briefly having an extra person's assistance can make installation that much easier. If you have questions regarding the installation of your new Full-Metal™ JackRabbit™ retractable tonneau cover, please call our Technical Support Line at (800) 338-3697 or visit our web site at www.paceedwards.com.

DRAIN HOLE LOCATIONS:

The JackRabbit is designed to carry rainwater from the fabric cover into the canister and then out through the drains. Most truck models have standard OE drain holes or plastic/rubber access ports in the front of the truck bed. Check to make sure your truck has the OE drain holes so that drilling into the sheet metal is not required. If drilling is necessary, be sure to check the underside of the truck bed for the best location. The holes should be located near the side and as far forward as possible. Use a drill bit suitable for sheet metal (such as a taper drill or step drill). Drill drain tube clearance holes at 3/4" (19mm). This will need to be done before installing the cover.

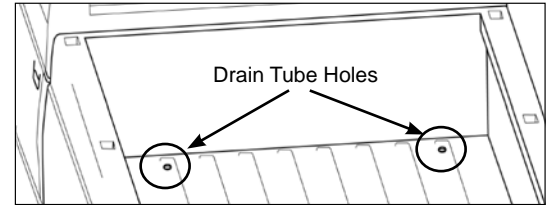

STEP 1: REMOVE PLYWOOD PACKAGING

Remove the canister from the box. Using the wrench or socket remove the 2 bolts holding the plywood on the ends of the canister. Discard plywood packaging and bolts.

Locate the rail guide bolts in the hardware pack and install them in the two holes where the packaging bolts and plywood were just removed. Repeat on both ends of the canister.



CAUTION! DO NOT USE A KNIFE TO OPEN THE RAIL BOX. OPEN THE RAIL BOX ALONG THE LENGTH OF THE BOX AND LIFT RAILS OUT TO AVOID SCRATCHING THE SURFACE OF THE RAILS ON THE PACKAGE STAPLES.

PACKAGING CONTENTS:

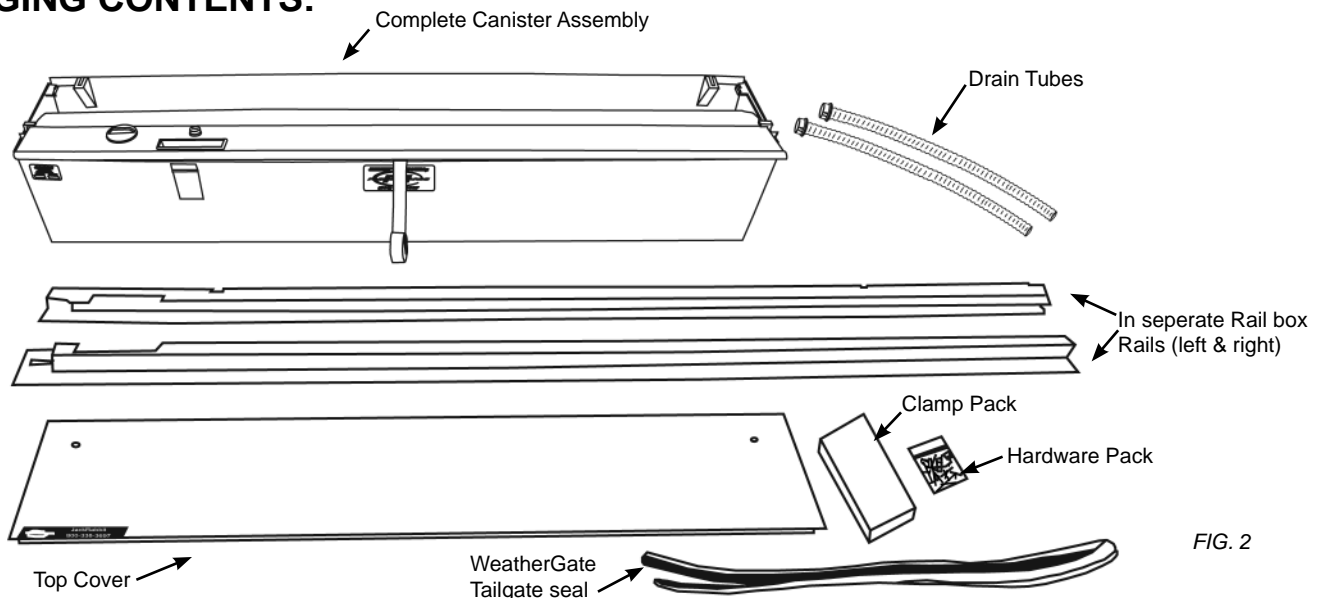

INSTALL TIP: IF YOU HAVE ANOTHER PERSON TO HELP STEADY THE CANISTER, IT MAY BE EASIER TO INSTALL THE RAILS (DESCRIBED IN STEP 2) BEFORE POSITIONING THE CANISTER IN THE TRUCK BED.

STEP 2: POSITIONING CANISTER

Remove the top cover from the canister box and set it aside for later installation. Perform a quick inventory to insure all parts are there. Be sure to check inside the small cardboard box for parts. You will need one or two support pieces (We suggest using the top of the box the Jackrabbit was shipped in.) to set in the truck bed approximately one foot from the cab that will go under the canister, raising the top of the canister above the bed rails by 2-3 inches. Remove the Canister from the box and set it on the support(s) in the truck bed.

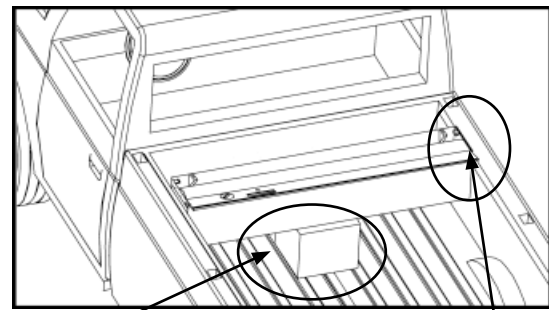

FIG. 3

Support Piece

Top of Canister should clear Truck Bed Rails by 2-3"

STEP 3: INSTALLING RAILS

Open the rail box along the length of the box; lift rails out to avoid scratching the rail surface on the package staples.

Determine what style rails you have. **STYLE A** will have a curved guide where the cover will slide into the rail. **STYLE B** does not have this curved piece. Proceed to the corresponding installation below.

STYLE A Rails:

Start by removing the blanket guides attached to each end of the canister (*Figure 4*) These were used to hold the cover in place for shipping. **DO NOT ALLOW THE COVER TO RETRACT INTO THE CANISTER WITHOUT PROTECTING THE UNDERSIDE OF THE LOCK ASSEMBLY. SERIOUS DAMAGE TO THE SURFACE MAY OCCUR IF THE COVER IS ALLOWED TO RETRACT.** Install the rails by sliding them down into the rail grips that are attached on the inside of the canister, slide them forward, towards the truck cab making sure that both ends of the rail grip are engaged. (*Figure 5*)

FIG. 4

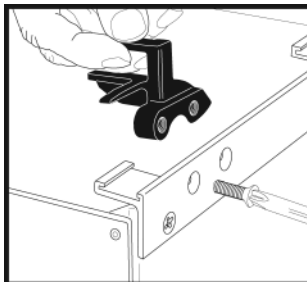

STYLE A RAILS ONLY!
Remove the blanket guides.

FIG. 5

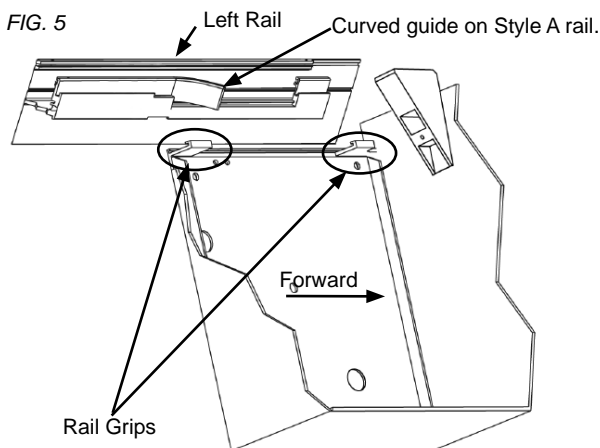

Rail Grips

FIG. 6

STYLE B Rails:

Install the rails by sliding the rails through the attached blanket guides on the canister threading the cover in the rails and sliding the rails into the rail grips that are attached on the inside of the canister. Then slide the rails forward, towards the truck cab making sure that both of the rail grips are engaged. (*Figure 6*)

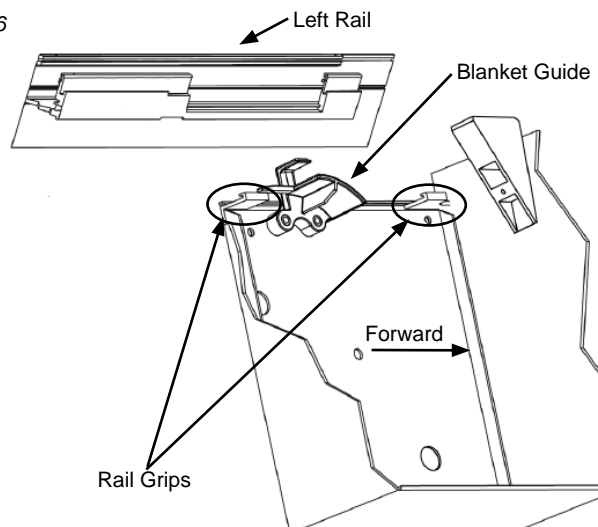

Rail Grips

STEP 4: REPOSITIONING CANISTER

Slide canister and rail assembly against the cab end of the truck bed. Remove the support(s) under the canister so that the canister and rails rest firmly on the sides of the truck bed.

STEP 5: INSTALLING CLAMPS

Before shimming and installing the rail clamps make sure the canister is centered between the truck bed rails.

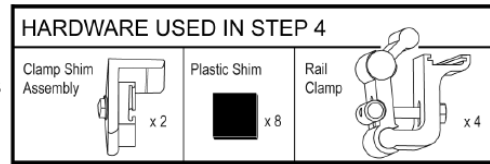

Not all truck beds are square. Shims may be required to keep the rails parallel and from bowing out when the clamps are tightened. If there is a space greater than $\frac{3}{8}$ " (in most cases at the cab end of the rails) in between the rail and the truck bed, then slide the adjustable clamp shims (*Figure 7*) down the rails 6-12" from the rail stops (installed in Step 3). Loosen the bolt on the clamp shim and slide the bracket up against the truck bed. Then tighten the bolt so the shim is held tight in place. If there is less than $\frac{3}{8}$ ", the adjustable clamp shim is not needed. Insert plastic shim(s) if necessary to level the rail when proceeding with installing the clamps (*Figure 8*). Add plastic shims to equalize the distance between rails at front and rear to obtain no more than a $\frac{1}{4}$ " side to side play in between the cover and rails.

Slide the front clamp rail grips (*Figure 9*) 6-12" inches from the rail stop, or if the adjustable clamp shim was installed, 1" from that shim on both the left and right side rails. (**Note: Clamp rail grip for Dodge Ram is $\frac{3}{4}$ " longer in the front than the rear.**) Slide rear clamp rail grips 6-12" from the tailgate on both the left and right rails. Install the tailgate end of the pull strap to the underside of the drivers side rail using the #8-32 x $\frac{3}{4}$ " machine screw located at the tailgate end on the underside of the rail. (*Figure 10*)

Assemble the pivot arms to the clamp rail grips and snug the bolts on the clamps so that the rails rest firmly against the truck bed. (*Figure 9*) Close the tailgate and position the rails with a $\frac{1}{16}$ " gap from the tailgate. Measure the distance between the rails at the canister and tailgate. This distance should be the same to allow your cover to operate properly. Once everything is square tighten the clamps completely.

FIG. 7

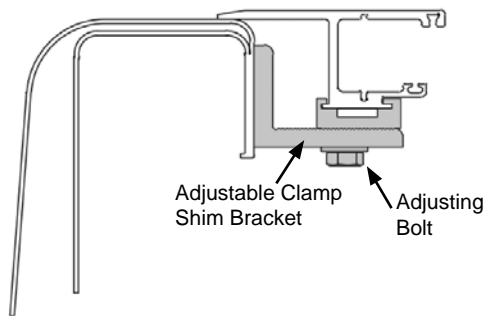

FIG. 8

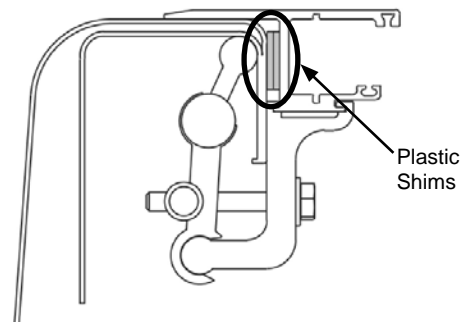

FIG. 9

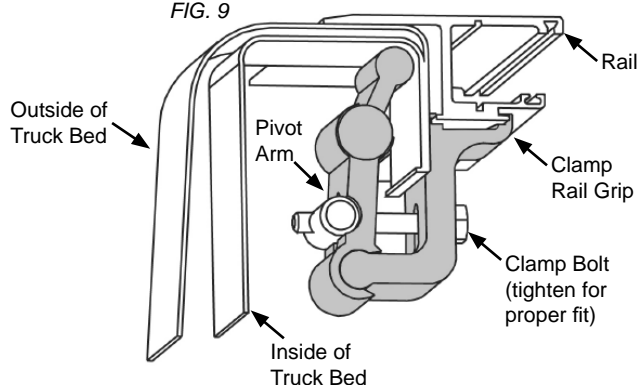
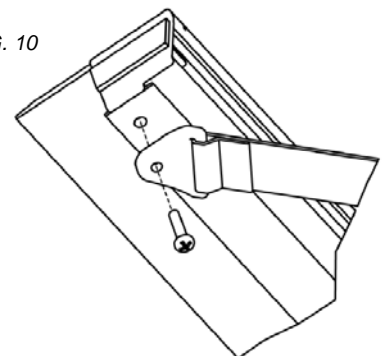

FIG. 10



STEP 6: LUBRICATING & PLACING THE SWEEP SEALS

Locate the sweep seals (rubber weather strips) on the rails. Apply Pace Edwards' UV Protectant (or suitable lubricant) to a rag and wipe the underside of the sweep seal and the top of the wear strip.

Extend the cover to the tailgate. Use an Allen wrench if needed to carefully draw out the sweep seal (seal should be angled outwards toward the cover – not rolled in toward the bed rail). (Fig. 11)

Proper care and placement of the sweep seal will ensure smooth operation of the cover. Alcohol, petroleum based or silicon-based cleaners such as Armor-All should be avoided and ARE NOT recommended for our covers.

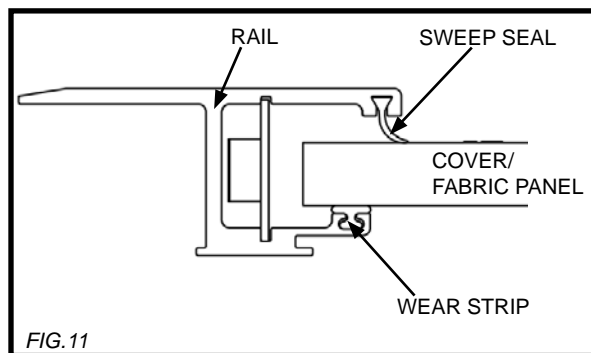

STEP 7: INSTALLING DRAIN TUBES

First ensure that the “o” ring is in place on the dRAINTUBE end being inserted into the canister (This will prevent water leakage). With the cover *opened*, insert the drain tube fittings into the pre-drilled holes on the underside of the canister by pushing them in place from under the canister. Drain tube should click into place. Place the other end of the drain tube through the grommet or through the pre-drilled holes in the floor or the front wall of the truck bed.

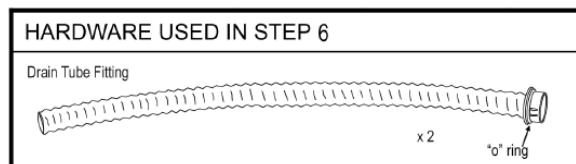

STEP 8: ATTACHING TOP COVER AND PULL STRAP VELCRO TO RAIL

Place the top cover on the canister. Fasten the top cover onto the canister with the two black top cover screws (we recommend that you use a threadlocking adhesive like Loctite® on the screws) going into the top cover mounting blocks. Retract the cover to the fully open position. Attach the 4” Velcro strip onto the Velcro strip already attached to the pull strap. Pull the pull strap over to the driver’s side rail and remove the tape from the 4” Velcro strip. Then apply the Velcro strip onto the underside of the rail at your desired position. This will hold the pull strap off of the floor and out of the way when cargo is being stored in the truck bed.

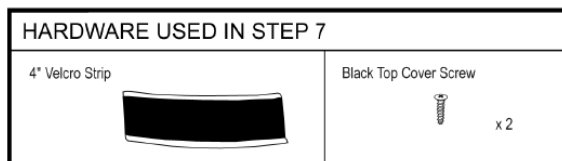
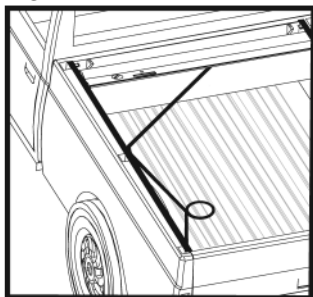

FIG. 12



Attach velcro to pullstrap and stick in your desired position anywhere along the underside of drivers side rail.

You have now completed the installation of your Full-Metal JackRabbit hard tonneau cover. If you have any questions please do not hesitate to call us at: (800) 338-3697 and ask for our technical service department.

OPERATING INSTRUCTIONS

1. To open the cover, turn the actuator knob clockwise 90° until it clicks in the open position. This retracts the latches into the handle and the cover is free to roll open into the canister. A tug on the pull strap will release the latch and allow the cover to lock into the rails.
2. To latch the cover in one of the mid-range positions, pull it back just beyond the position desired and allow the cover to retract until it latches into place. Latching positions are located every 12 inches along the rails. The clicking sound is the spring-loaded latches mounted inside the handle. The latches are designed to bypass the latching positions as the cover is being closed and to stop the cover as it is being retracted.
3. To close the cover, pull on the strap to draw it back toward the tailgate. When it is within easy reach, grasp the handle by the handgrip and pull the cover to the latching position against the tailgate.
4. To use the key lock, position the cover on the truck bed with the actuator knob in the closed position and turn the key.

HELPFUL MAINTENANCE HINTS

To assure quiet, smooth operation, apply a small amount of grease (we suggest white lithium grease) to the wear strips where the metal end of the panels and the wear strips meet. This initial application should be sufficient for a year or more. Regrease the wear strips if the cover begins squeaking during use.

It is important to open and close the cover regularly; the spring that operates the cover is self-lubricated and regular use assures that it stays in proper working condition.

Drain tubes may become clogged overtime and should be removed and cleaned. To remove the drain tubes you must depress the plastic retaining tabs on the drain tube fittings and pull the drain tube out of the hole in the bottom of the canister.

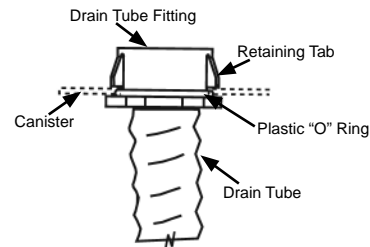

Periodically remove the Top Cover and clean out the canister.

To help keep the Full-Metal JackRabbit tonneau cover looking it's best, we recommend washing it the same as caring for your truck finish. However due to the hammer texture, removal of wax can be difficult so you should not wax your cover.

2400 Commercial Blvd, Centralia, WA 98531 USA
(360) 736-9991 (main) ♦ (360) 736-9992 (fax)
(800) 338-3697 (toll-free)
www.paceedwards.com

Thank you for choosing products by...

