

JACK RABBIT™

RETRACTABLE HARD TONNEAU COVER

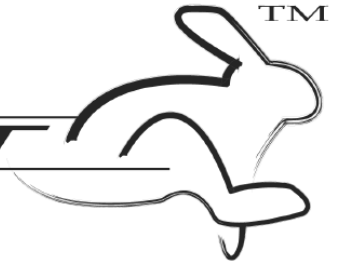

INSTALLATION INSTRUCTIONS 2005 Colorado Crew Cab



Pace Edwards Company
2400 Commercial Blvd.
Centralia WA 98531

(800) 338-3697 toll free
(360) 736-9991 main
(360) 736-9992 fax

www.paceedwards.com

Part #: JR-CCC-INSTALL 035

TABLE OF CONTENTS

Tools Required for Assembly	2
Before You Start	2
Drain Hole Locations (FIG. 1).....	2
Packaging Contents (FIG. 2)	2
Hardware Kit Supplied with Unit (FIG.3)	3
STEP 1: Positioning Canister (FIG. 4)	3
STEP 2: Install & Fasten Rails (FIG. 5).....	4
STEP 3: Fasten Canister (FIG. 6)	4
STEP 4: Lubricating & Placing Sweep Seals (FIG. 7).....	5
STEP 5: Assembling Pull Strap & Handle (FIG. 8 & 9).....	5
STEP 6: Installing Drain Tubes.....	6
STEP 7: Install Top Cover & Velcro to Pull Strap	6
Operating Instructions	6
Helpful Maintenance Hints	6
Warranty Statement.....	7

TOOLS REQUIRED FOR ASSEMBLY:

7/16" wrench or socket
7/8" socket, ratchet
3/32" Allen wrench
#2 Philips screwdriver
Wire cutters

Pliers for spring clip
Threadlocking adhesive (such as Henkel's *Loctite*®)
UV Protectant or Petroleum-based lubricant
Rag

Note: There should be no drilling into the truck body needed but the drain tube holes may need to be made larger.

BEFORE YOU START:

Read the instructions carefully before you start. These instructions are written for one-person installation. We have noted in a couple of places where briefly having an extra person's assistance can make installation easier. If you have questions regarding the installation of your new JackRabbit® retractable tonneau cover, please call our Technical Support Line at (800) 338-3697 or visit our web site at www.paceedwards.com.

DRAIN HOLE LOCATIONS:

The JackRabbit® is designed to carry rainwater from the fabric cover into the canister and then out through the drains. Most truck models have standard OE drain holes or plastic/rubber access ports in the front of the truck bed. Check to make sure your truck has the OE drain holes so that drilling into the sheet metal is not required. If drilling is necessary, be sure to check the underside of the truck bed for the best location. The holes should be located near the side and as far forward as possible. Use a drill bit suitable for sheet metal (such as a taper drill or step drill). Drill drain tube clearance holes at 5/8" (16mm). This will need to be done before installing the cover.

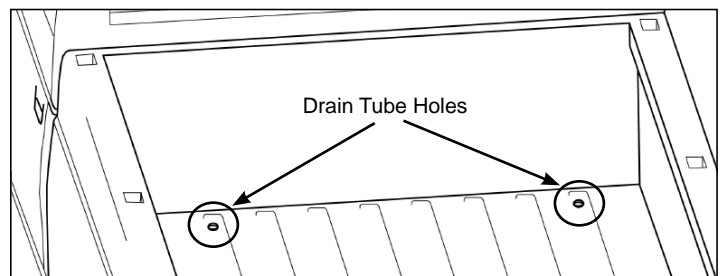
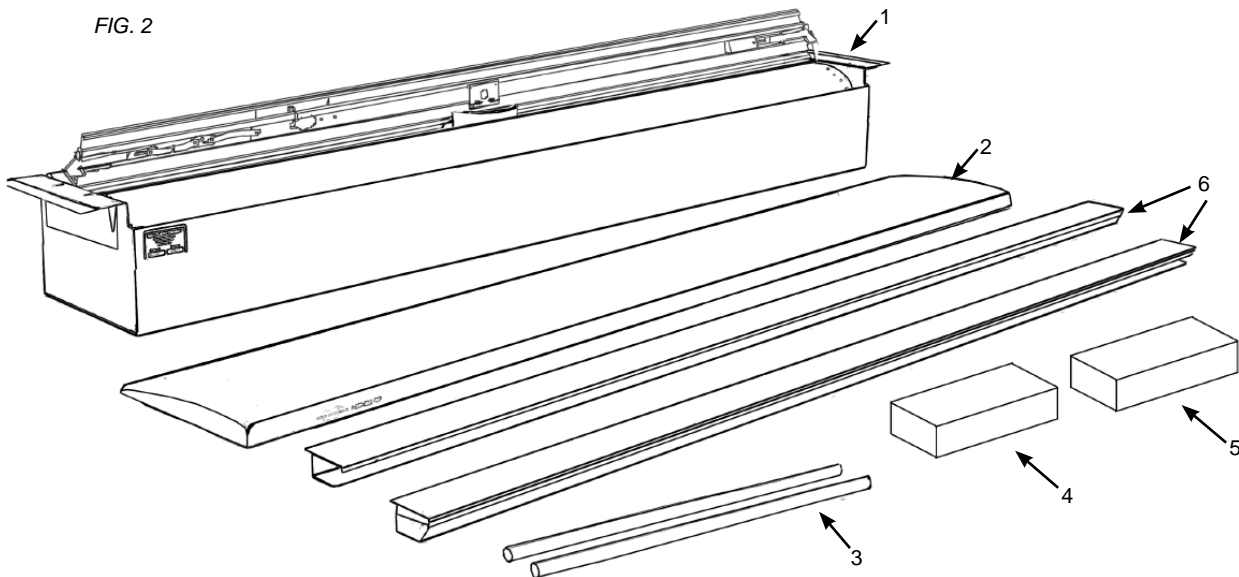

FIG. 1

PACKAGING CONTENTS:

FIG. 2



CONTENTS IN CANISTER BOX











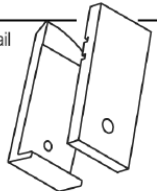



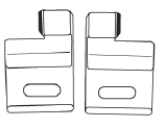



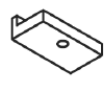









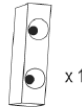

1. Complete Canister Assembly
2. Top Cover
3. Drain Tubes
4. Clamp Pack
5. Hardware Pack

CONTENTS IN RAIL BOX

6. Rails (left & right)

HARDWARE KITS SUPPLIED WITH UNIT:

FIG. 3

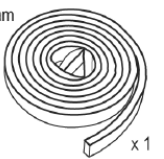
STEP 2							
Plastic Shim  x 8	Outer & Inner Rail Clamps  x 4	Rail Clamp 1/4" Flat Washer  x 4	Rail Clamp 1/4" Lock Washer  x 4	Rail Clamp Bolt  x 4			
STEP 3							
Rail Stop (Left & Right) 	Rail Stop Bolt (1/4"-20 x 3/4")  x 2	3/16" Flat Washer  x 2	1/4" Lock Washer  x 2	Canister Clamp  x 2	Clamp Bolt (1/4" - 20)  x 2	Fender Washer  x 2	
STEP 5							
Pull Strap  x 1	Hex Bolt (1/4"-20 x 5/8")  x 1	1/4" Flat Washer  x 2	Pull Strap Screw (8-32 x 3/4")  x 1	Handle Stop  x 2	Handle Stop Screw (8-32 x 3/4" pan head)  x 4	Lock Cylinder  x 1	Lock Cylinder Nut  x 1
	Lock Cylinder Screw & Spider Nut  x 1	Lock Tab  x 1	Lock Keys 	Lock Link Block  x 1	Lock Link Block Screw (8-32 x 3/4" flat head)  x 2	Hand Grip  x 1	
STEP 6				STEP 7			
Drain Tube Fitting  x 2	Drain Tube Fitting Clamp  x 2	4" Velcro Strip 	Black Top Cover Screw  x 4	Plastic Canister Insert  x 4	Foam  x 1		

STEP 1: POSITIONING CANISTER

Remove the top cover from the canister box and set it aside for later installation. Perform a quick inventory to insure all parts are there. Be sure to check inside the small cardboard box for parts. Remove the Canister from the box and set it in the truck bed against the cab. The canister should be resting on the canister end plates and be centered in the truck bed.

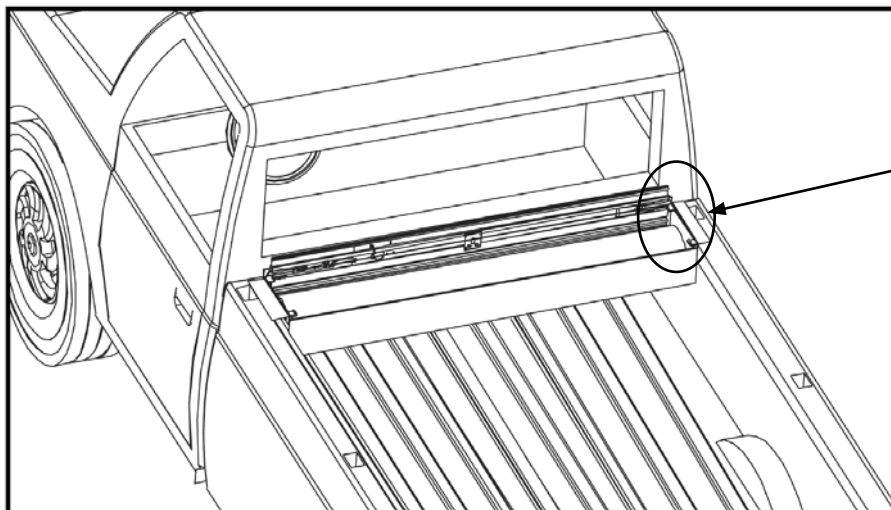

Canister should be resting on the end plates and be centered in the bed against the cab.

FIG. 4

CAUTION! DO NOT USE A KNIFE TO OPEN THE RAIL BOX. OPEN THE RAIL BOX ALONG THE LENGTH OF THE BOX AND LIFT RAILS OUT TO AVOID SCRATCHING THE SURFACE OF THE RAILS ON THE PACKAGE STAPLES.

STEP 2: INSTALL & FASTEN THE RAILS

Open the rail box along the length of the box; lift rails out to avoid scratching the rail surface on the package staples. The side rails are marked "left" and "right" (left is the driver's side of the truck). With the tailgate closed, place the side rails in position on the truck bed. Side rails have a rubber spacer on the end caps, at the tailgate end, to establish the correct spacing to the tailgate (1/16") and to prevent the tailgate from striking the side rails when closing. Press the rail tightly against the closed tailgate. Shims may be required to maintain a horizontal top surface on the rails. Peel and stick the shims to the back side of the rail brackets (or the side that will be against the truck). Shims are provided in two thicknesses. Shims may need to be stacked on each other to create the right thickness. Repeat the same process on each side.

Place the four (4) clamps over the brackets located on the underside of the rails. Apply downward pressure while tightening the clamps on the rails, especially on the tailgate end. This will ensure a tight seal, firm seat, and good fit on the truck bed. Locate the top groove of the inner clamp bracket onto the lip of the rail bracket (as shown Fig. 5). Rotate the outer clamp bracket clockwise to tighten rail downward against bed rail. Tighten bolt securely. (*Adjust pressure against tailgate by moving rails forward or backward as needed prior to final tightening of clamps.*)

**DO NOT TIGHTEN OVER
120-INCH POUNDS!**

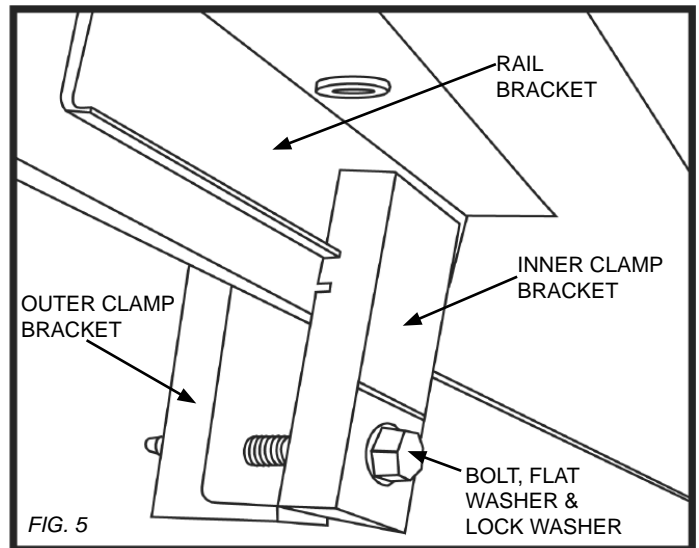

INSTALL TIP: TO MAKE RAIL INSTALLATION EASIER YOU MAY WANT TO HAVE ANOTHER PERSON HOLD THE RAILS IN PLACE WHILE YOU ARE TIGHTENING THE CLAMPS. YOU CAN ALSO TEMPORARILY TAPE THE RAILS IN PLACE WHILE TIGHTENING THE CLAMPS IF ANOTHER PERSON IS NOT AVAILABLE.

STEP 3: FASTEN CANISTER

Slide canister against the cab side of the bed so that the canister and rails rest firmly on the sides of the truck bed. Slide the rail stops on the rail up to the canister. Position the rail stops snug up against the canister. Then use the 1/4"-20x3/4" hex bolt, 3/16" flat washer and 1/4" lock washer to tighten the rail stops in place, utilizing the existing threaded hole on the underside of the rail. Center the canister side-to-side on the truck bed and fasten it in place with the canister clamps. Use one clamp per side of canister. Install 1/4" - 20 bolt with fender washer through one of the slots in each end of the canister and attach the Canister Clamp. (Fig. 6)

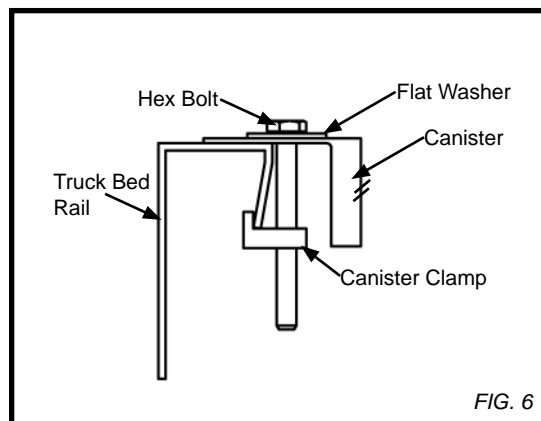

STEP 4: LUBRICATING & PLACING THE SWEEP SEALS

Locate the sweep seals (rubber weather strips) on the rails. Apply Pace Edwards' UV Protectant (or suitable lubricant) to a rag and wipe the underside of the sweep seal and the top of the wear strip. Carefully remove the ZIP tie securing the cover to the canister we recommend using the wire cutters for this. Roll the handle down into the ends of the rails and down to the tailgate. Using an Allen wrench to carefully draw out the sweep seal (seal should be angled outwards toward the cover – not rolled in toward the bed rail).(Fig. 7) Proper care and placement of the sweep seal will ensure smooth operation of the cover. Remove the protective foam cover from the underside of the fabric panel. Remove the protective film from the inside back of the canister. **DO NOT ALLOW THE HANDLE TO ROLL INTO THE CANISTER AS PERMANENT DAMAGE MAY OCCUR TO THE FABRIC.**

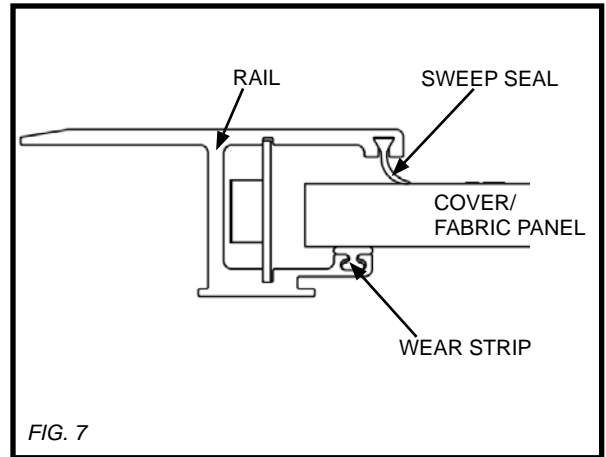

CAUTION!: PERMANENT DAMAGE MAY BE CAUSED IF THE HANDLE ASSEMBLY IS ALLOWED TO RETRACT INTO THE CANISTER WITHOUT PROTECTION ON THE UNDERSIDE OF THE FABRIC PANEL!

STEP 5: ASSEMBLING PULL STRAP AND HANDLE

Install 1/4-20 x 5/8" hex bolt, 1/4" flat washer and handle end of pull strap into the center block on the handle (we recommend that you use a threadlocking adhesive such as Loctite® on the pull strap bolt). Fasten the tailgate end of the pull strap to the underside of the left hand rail using a #8-32 x 3/4" pan head screw.(Fig. 8)

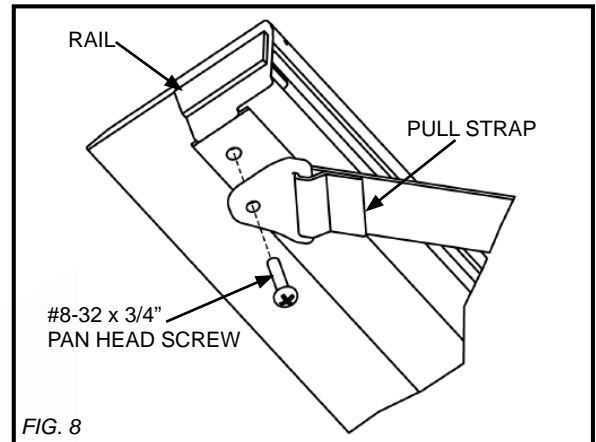

Install the handle stops onto the underside of the handle using #8-32x3/4" pan head screws and insert the lock cylinder into the lock hole on the handle. Tighten the lock cylinder nut using a 7/8" socket wrench. Install the lock tab onto the lock cylinder with the lock cylinder screw and 1/4" spider lock washer so the tab points to the passenger side of the truck. Next, install the lock link block under the handle with (2 ea) #8-32x3/4" flat head screws.

Insert the handgrip into the handle cutout so that the angled side is towards the truck cab then pull back to snap the handle into place.

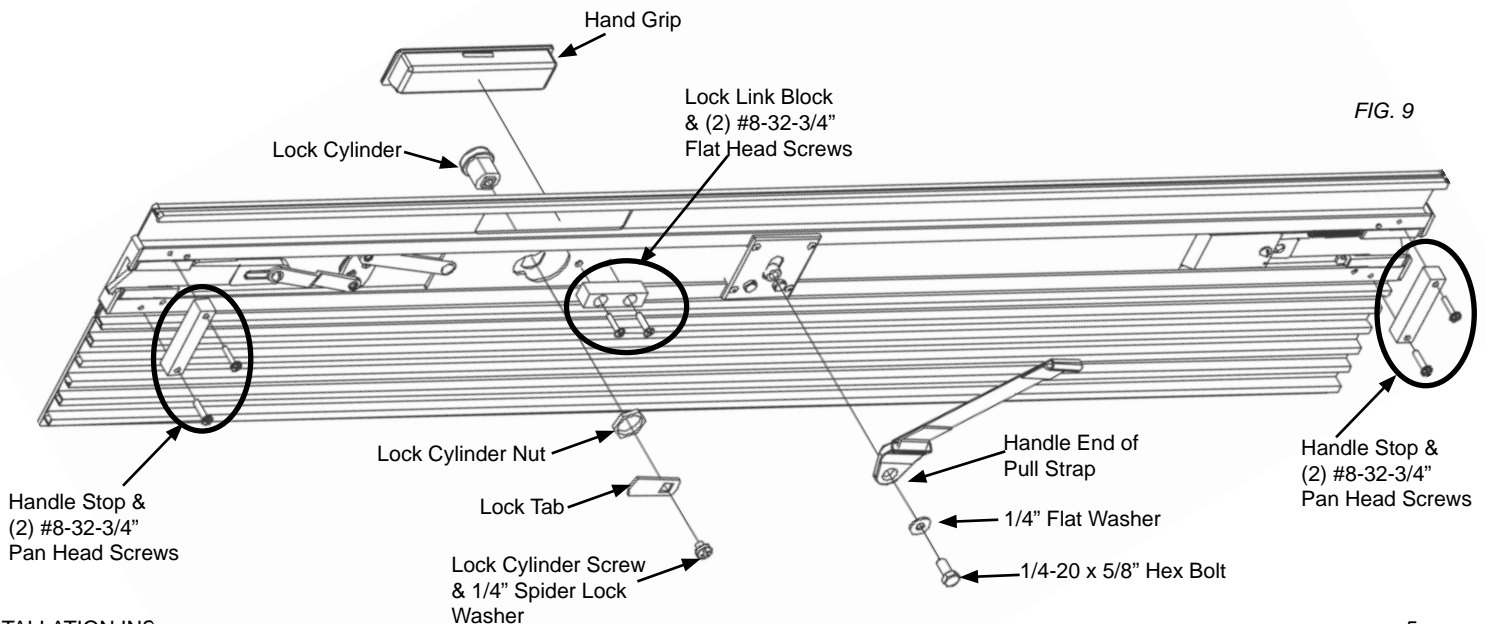

STEP 6: INSTALLING DRAIN TUBES

With the cover *closed*, insert the drain tube fittings into the pre-drilled holes on the underside of the canister by popping them in place from the inside of the canister. With the cover *open*, place the drain tubes onto the tube fittings. Attach the drain tube fitting clamp over the hose and fitting. Place the other end of the drain tube through your grommet in the truck bed or through the pre-drilled holes in the floor on the front wall of your bed.



INSTALL TIP: TO MAKE THE DRAIN TUBE INSTALLATION EASIER YOU MAY WANT TO HAVE ANOTHER PERSON HOLD THE TUBE FITTINGS IN PLACE WHILE YOU ATTACH THE DRAIN TUBES AND DRAIN TUBE CLAMPS TO THEM FROM UNDERNEATH THE CANISTER.

STEP 7: ATTACHING TOP COVER AND VELCRO TO PULL STRAP

Insert the plastic canister inserts into the square holes located on either side of the canister. Place the Top Cover on the canister and install with the four long Top Cover screws. Tighten the screws until the cover is just touching the truck bed. Be sure the high side showing the label faces the tailgate. **Do not over tighten.** Foam is provided to close up the front of the top cover if needed.

Attach the 4" Velcro strip onto the Velcro strip already attached to the pull strap. Pull the pull strap over to the driver's side rail and remove the tape from the 4" Velcro strip. Then apply the Velcro strip onto the underside of the rail at your desired position.

You have now completed the installation of your JackRabbit hard tonneau cover. ***Leave cover closed for 24 hours before operating regularly to allow the sweep seal to form into place (refer to end of Step 5). Proper care in placement of the sweep seal now will ensure smooth operation of the cover.***

OPERATING INSTRUCTIONS

1. To open the cover, turn the actuator knob clockwise 90° until it clicks in the open position. This retracts the latches into the handle and the cover is free to roll back into the canister. A tug on the pull strap will release the latch and allow the cover to lock into the rails.
2. To latch the cover in one of the mid-range positions, pull it back just beyond the position desired and allow the cover to retract until it latches into place. Latching positions are located every 12 inches along the rails. The clicking sound is the spring-loaded latches mounted inside the handle. The latches are designed to bypass the latching positions as the cover is being closed and to stop the cover as it is being retracted.
3. To close the cover, pull on the strap to draw it back toward the tailgate. When it is within easy reach, grasp the handle by the handgrip and pull the cover to the latching position against the tailgate.
4. To use the key lock, position the cover on the truck bed with the actuator knob in the closed position and turn the key.

HELPFUL MAINTENANCE HINTS

To assure quiet, smooth operation, apply a small amount of grease to the wear strips where the metal end of the panels and the wear strips meet. This initial application should be sufficient for a year or more. Regrease the wear strips if the cover begins squeaking during use.

It is important to open and close the cover regularly; the spring that operates the cover is self-lubricated and regular use assures that it stays in proper working condition.

Drain tubes may become clogged overtime and should be removed and cleaned. Periodically remove the Top Cover and clean out the canister.

To help keep the JackRabbit tonneau cover looking it's best, we recommend washing it the same as caring for your truck finish. However you should not wax your cover. Using a citrus-based vinyl cleaner and protectant such as Pace Edwards Brand or the 303 brand will keep your cover looking like new. Alcohol, petroleum based or silicon-based cleaners such as Armor-All should be avoided and ARE NOT recommended for our covers.

WARRANTY STATEMENT

Pace Edwards Company prides itself in fast, friendly warranty service for all of our products. Our goal is to design quality into everything we make.

We warrant our products to be free from defects in material and workmanship under normal use for **one year from the date of purchase**. In the event of defect in materials or workmanship, we will warrant parts only at no charge, which in our judgment show evidence of such defect within one year from date of purchase.

This warranty is void if the product has direct or indirect damage resulting from accident, misuse or abuse, lack of reasonable care, modifications, alterations, loss of parts, normal wear and tear, acts of god, improper installation or damage during shipping. This warranty does not cover installations on commercial vehicles or to trucks used for racing or off-road. This warranty is void when service or repair is performed by a non-approved service center.

At the end of the warranty period, Pace Edwards Company shall be under no further warranty obligation, express or implied. No other warranty or affirmation of fact, written or oral, is authorized or made by Pace Edwards Company and the terms of this warranty constitute the purchaser's sole and exclusive remedy.

This warranty gives the purchaser specific legal rights and the purchaser may also have other rights that may vary from state to state.

WARRANTY REQUIREMENTS:

- 1) **Original sales receipt**
- 2) **Product returned must be in original packaging**
- 3) **Product Serial Number**
- 4) **Product Model Number**

For your convenience, you may register your warranty claim at Pace Edwards' web site at www.paceedwards.com. This will help expedite your warranty claim. If you need warranty assistance, please call (800) 338-3697 and one of our technical service reps will be happy to help you. Please have your model and serial numbers and your original sales receipt available when you call.

2400 Commercial Blvd, Centralia, WA 98531 USA
(360) 736-9991 (main) ♦ (360) 736-9992 (fax)
(800) 338-3697 (toll-free)
www.paceedwards.com

Thank you for choosing products by...

