

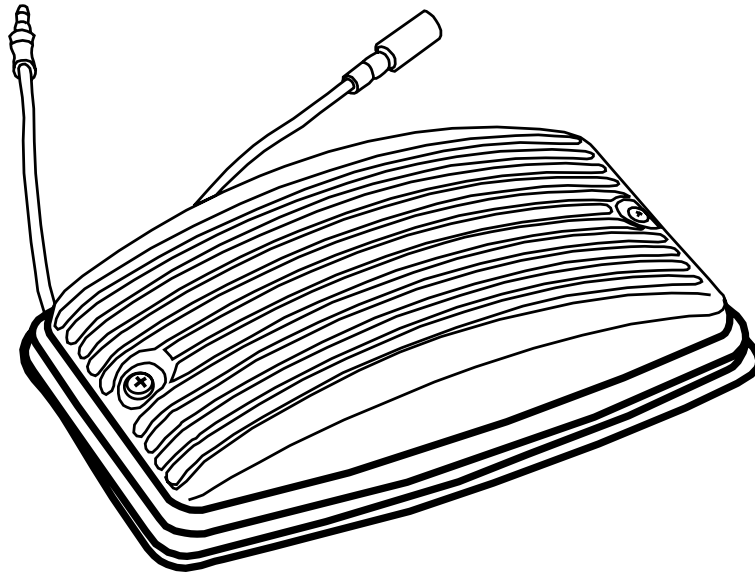

RETRACTABLE HARD TONNEAU COVER

CARGO LIGHT KIT ASSEMBLY INSTRUCTIONS



Pace Edwards Company
2400 Commercial Blvd.
Centralia WA 98531

(800) 338-3697 toll free
(360) 736-9991 main
(360) 736-9992 fax

www.paceedwards.com

TABLE OF CONTENTS

Tools Required for Assembly	2
Before You Start	2
Packaging Contents	2
STEP 1: Attaching Light to Canister	3
STEP 2: Routing Light Wires.....	3
STEP 3: Installing Light Switch, Relocate Pull Strap...	3
STEP 4: Attaching Black Light Wire & Ground Wire....	4
STEP 5: Connecting Fuse Link	4

TOOLS REQUIRED FOR ASSEMBLY:

5/16" wrench or socket
3/32" Allen Wrench
#2 Philips screwdriver

Flat Head Screwdriver
Electric Drill
9/64" Drill Bit

BEFORE YOU START:

Read the instructions carefully before you start. If you have questions regarding the installation of your JackRabbit® Light Kit, please call our Technical Support Line at (800) 338-3697 or visit our web site at www.paceedwards.com.

PACKAGING CONTENTS:

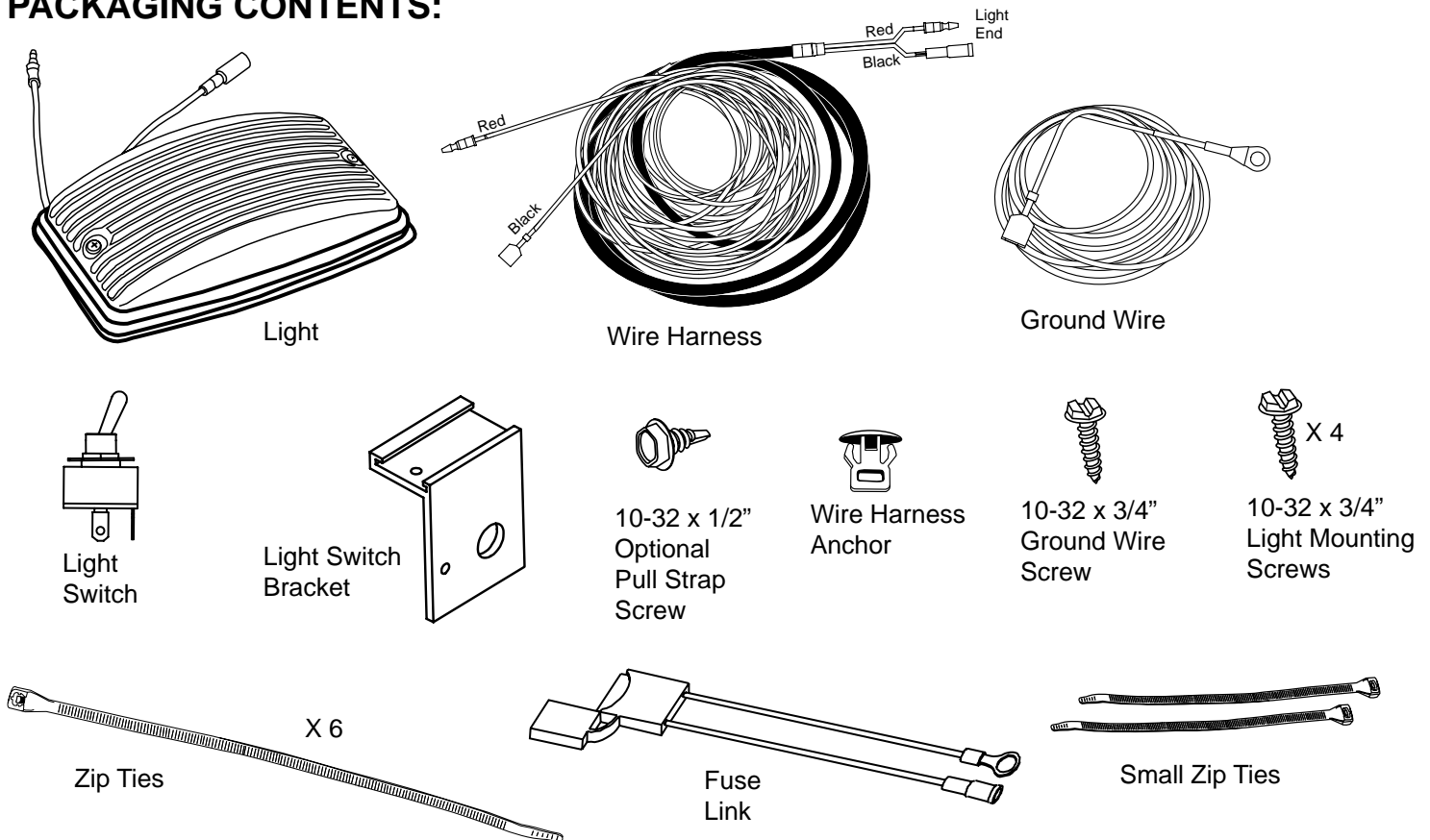

NOTE TO INSTALLER:

If the JackRabbit Cover has already been installed and you are installing the light kit you will need to follow the steps below. If you are installing the Light Kit and the Tonneau Cover at the same time proceed to the next page.

1. Unscrew the screws and remove the Top Cover from the canister.
2. Disassemble the Handle Stops from the underside of the Handle Assemble.
3. Retract the handle from the rails into the canister **USING EXTREME CAUTION TO PROTECT THE BLANKET FABRIC FROM THE HANDLE ASSEMBLY. USE A CLOTH, TOWEL OR PACKAGING MATERIAL IN BETWEEN THE HANDLE ASSEMBLY AND THE COVER TO PREVENT PERMANENT DAMAGE TO THE COVER.**

CAUTION! PERMANENT DAMAGE MAY BE CAUSED IF THE HANDLE ASSEMBLY IS ALLOWED TO RETRACT INTO THE CANISTER WITHOUT PROTECTION ON THE UNDERSIDE OF THE HANDLE ASSEMBLY !

4. Proceed to install the light as outlined in the steps on the next pages. Disregard the notes that make reference to the standard installation of the cover. When finished with the installation of the light reverse the above directions to complete the installation.

NOTE: *The JackRabbit Instructions that came with your cover should be followed up to STEP # 3 before attaching the Cargo Light.*

STEP 1: ATTACHING LIGHT TO CANISTER

Pierce the holes through the JackRabbit Sticker at the center of the canister or remove the sticker entirely by peeling it off. Insert the Wire Harness Anchor into the smaller hole on the upper left of the hole pattern. Thread the wires attached to the light through the larger hole in the canister. Attach the light to the canister using the #10- 32 x 3/4" screws.

STEP 2: ROUTING LIGHT WIRES

The following instructions route wiring for the cargo light switch to be installed under the left-hand bed rail at the tailgate (Note: You may choose to install this switch on your dash). Route the light end of the Wiring Harness through the hole in the left end of the canister and connect them to the light wires. Secure the Wiring Harness to the canister using the Wiring Harness Anchors and Small Zip Ties. Route the red and black wires from the side of the canister through the side port of the stake pocket or other existing OE port/holes. (Note: Some truck models may not have holes in the stake pockets -- if a suitable OE hole is not available, it may be necessary to drill a hole.) Run the red wire along the frame and up to the battery area (**do not connect to the battery yet -- that will happen in Step 5**). Take the black wire and run it along the frame and up through the rear stake pocket (Optional: You may prefer running the black wire along the underside of the bed rails to the light switch). Try following OEM wire routes whenever possible. Secure the wires using the Zip Ties to ensure no loose or dangling wire. Keep the wires away from heat or sharp edges. *Note: It is always a good idea to wear eye protection when working under the vehicle to prevent debris from falling into your eyes.*

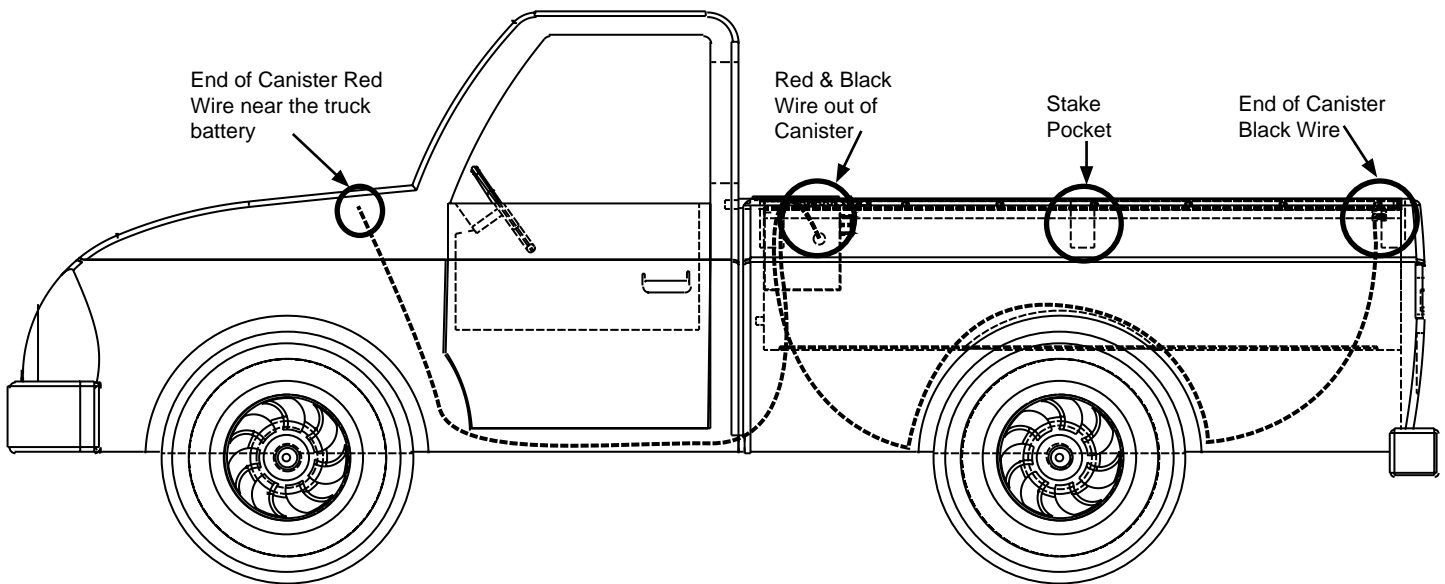

NOTE: *Proceed with STEPS # 3-5 in the JackRabbit Instructions.*

STEP 3: INSTALLING THE LIGHT SWITCH, RELOCATE PULL STRAP

Install the Light Switch by removing the nut and the on/off plate from the front of the switch. Insert the switch through the rear of the Light Switch Bracket, then reattach the on/off plate and nut to the Light Switch. Tighten the set screw on the light switch bracket using a 3/32" Allen Wrench. OPTIONAL: Using the #10-32 x 1/2" Pull Strap screw attach the Tailgate End of the pull strap to the Light Switch Bracket.

NOTE: *Proceed with STEP 6 in the JackRabbit Instructions.*

STEP 4: ATTACHING BLACK LIGHT WIRE AND GROUND WIRE

Attach the black wire from the canister onto either post on the back of the light switch. Then attach the black ground wire onto the other post on the light switch. Run the ground wire from the light switch through the rear stake pocket and down to the frame. Using an electric drill and the 9/64" drill bit, drill a pilot hole into the frame. Now attach the ground wire into the pilot hole using the #10-32 x 3/4" ground wire screw.

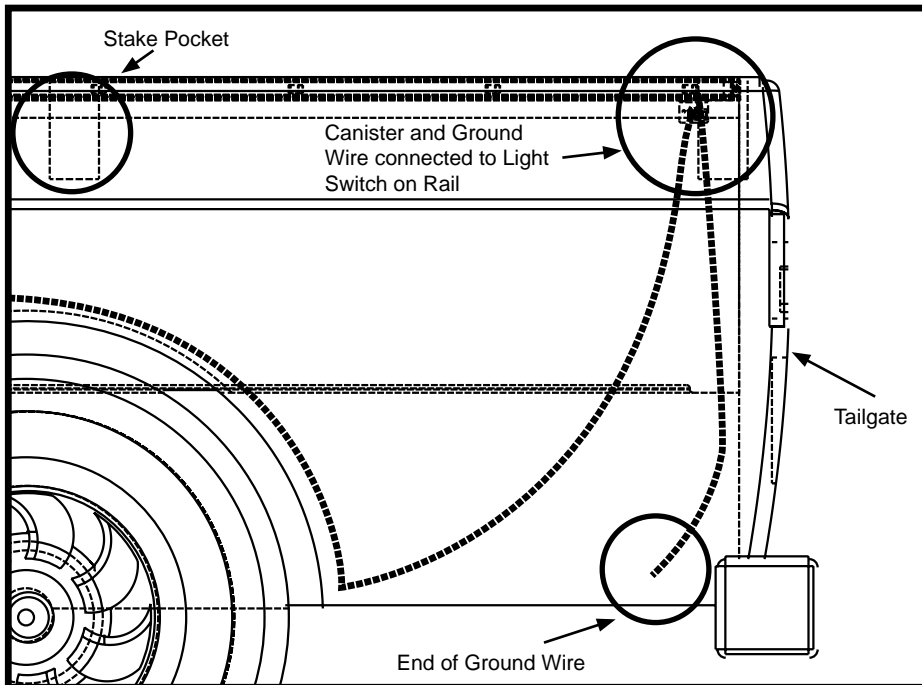

NOTE: Proceed with STEP 7-9 in the JackRabbit Instructions.

STEP 5: CONNECTING FUSE LINK

Connect the Fuse Link's open end to the end of the canister (wire harness) red wire near the battery. Detach the positive side of the battery's cable and attach the fuse link's O-ring end to the positive side of the battery. Reattach the battery cable.

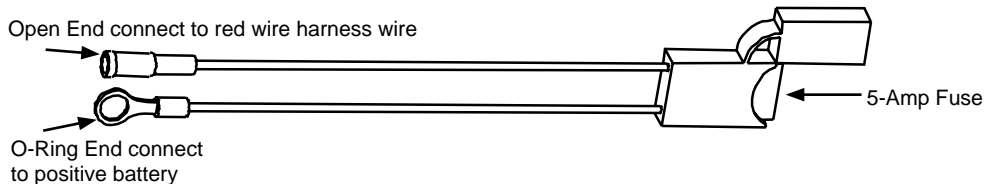

WARNING: A 5-AMP FUSE IS PROVIDED. SUBSTITUTING A FUSE LARGER THAN 5-AMPS WILL VOID ALL WARRANTY.

Installation of your JackRabbit Cargo Light is complete. To operate the light, flip the switch located at the rear of the left rail.