

# ROLL-TOP-COVER®

RETRACTABLE HARD TONNEAU COVER

## INSTALLATION INSTRUCTIONS 2005 Colorado Crew Cab



### TABLE OF CONTENTS

Tools Required for Assembly .....	2
Before You Start .....	2
Drain Hole Locations (FIG. 1).....	2
Packaging Contents (FIG. 2) .....	2
Hardware Kit Supplied with Unit (FIG.3) .....	3
STEP 1: Remove Contents from Box .....	3
STEP 2: Place Canister.....	3
STEP 3: Install Rails (FIG. 4) .....	4
STEP 4: Install Guide Strips (FIG. 5a, 5b).....	4
STEP 5: Fasten Canister (FIG. 6) .....	4
STEP 6: Lubricating Sweep Seal .....	5
STEP 7: Install Lock Arm Assembly (FIG. 7a, 7b, 8).....	5
STEP 8: Adjust Position of Guide Strips (FIG. 9) .....	6
STEP 9: Adjust Lock Arm Assembly .....	6
STEP 10: Install Drain Tubes (FIG. 10).....	6
STEP 11: Install Top Cover .....	6
Warranty Statement.....	7
Helpful Maintenance Hints .....	7



**Pace Edwards Company**  
2400 Commercial Blvd.  
Centralia WA 98531

**(800) 338-3697** toll free  
**(360) 736-9991** main  
**(360) 736-9992** fax

**[www.paceedwards.com](http://www.paceedwards.com)**

## TOOLS REQUIRED FOR ASSEMBLY:

7/16" wrench or socket  
5/16" wrench or socket  
7/8" socket, ratchet  
3/32" Allen wrench  
#2 Philips screwdriver

Wire cutters  
Pliers for spring clip  
Petroleum-based lubricant

*Note: There should be no drilling into the truck body needed but the drain tube holes may need to be made larger.*

## BEFORE YOU START:

Read the instructions carefully before you start. These instructions are written for one-person installation. We have noted in a couple of places where briefly having an extra person's assistance can make installation easier. If you have questions regarding the installation of your new Roll-Top-Cover® retractable tonneau cover, please call our Technical Support Line at (800) 338-3697

## DRAIN HOLE LOCATIONS:

The Roll-Top-Cover® is designed to carry rainwater from the fabric cover into the canister and then out through the drains. Most truck models have standard OE drain holes or plastic/rubber access ports in the front of the truck bed. Check to make sure your truck has the OE drain holes so that drilling into the sheet metal is not required. If drilling is necessary, be sure to check the underside of the truck bed for the best location. The holes should be located near the side and as far forward as possible. Use a drill bit suitable for sheet metal (such as a taper drill or step drill). Drill drain tube clearance holes at 5/8" (16mm). This will need to be done before installing the cover.

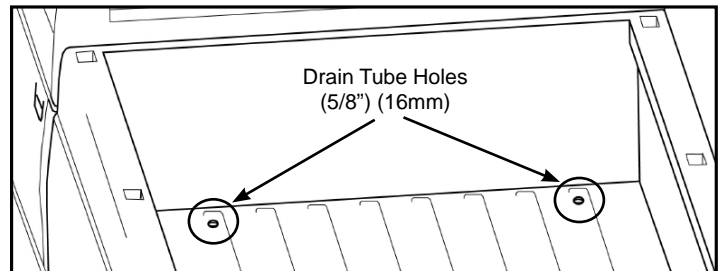
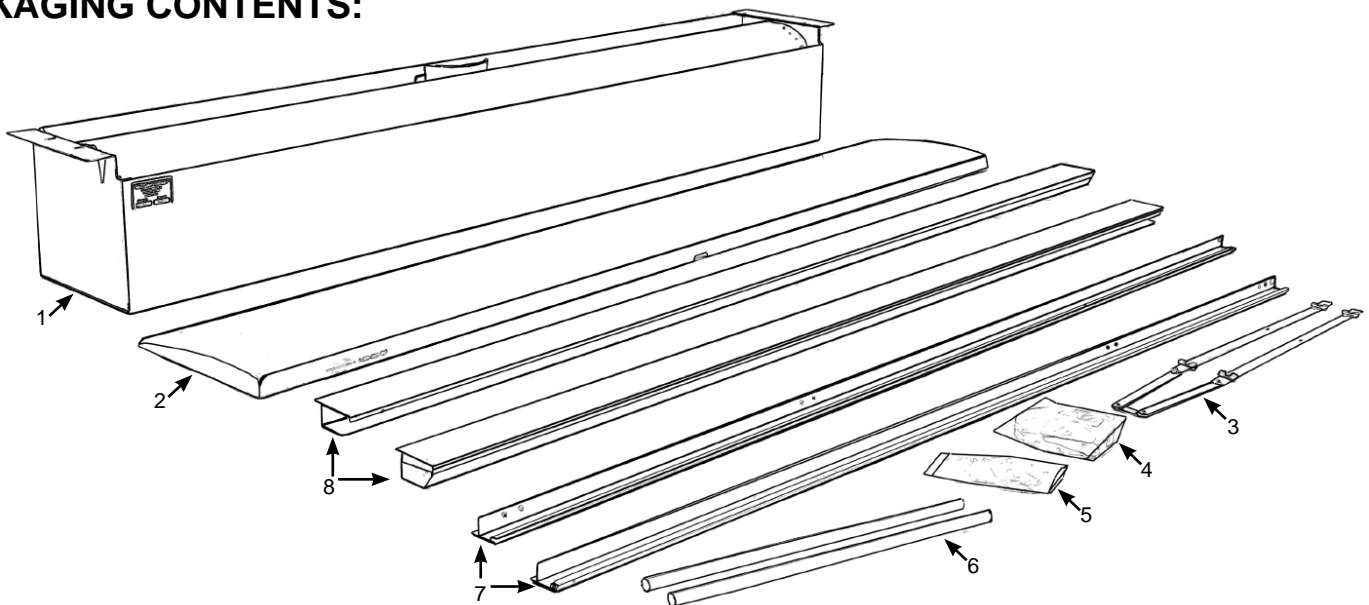

FIG. 1

## PACKAGING CONTENTS:

FIG. 2



### CONTENTS IN CANISTER BOX











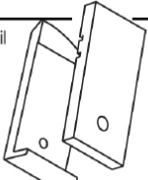





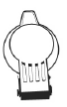

1. Canister Assembly
2. Top Cover Assembly
3. Lock Arm Assembly
4. Hardware Pack
5. Shim Pack
6. Drain Tubes

### CONTENTS IN RAIL BOX

7. Guide Strips (left & right)
8. Rails (left & right)

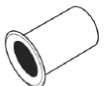
# HARDWARE KITS SUPPLIED WITH UNIT:

FIG. 3

<b>STEP 3</b>				
Plastic Shim  x 8	Outer & Inner Rail Clamps  x 4	Rail Clamp 1/4" Flat Washer  x 4	Rail Clamp 1/4" Lock Washer  x 4	Rail Clamp 1/4"-20 Bolt  x 4
<b>STEP 4</b>		<b>STEP 5</b>		
#8 Machine Screw  x 4	Canister Clamp  x 2	Clamp Bolt (1/4" - 20)  x 2	Fender Washer  x 2	
<b>STEP 6</b>				
Lock Arm Assembly  x 1				
Lock Cylinder  x 1	Lock Cover  x 1	Lock Cylinder Nut  x 1	Lock Cylinder Screw & Spider Nut  x 1	Lock Keys  x 1
<b>STEP 9</b>		<b>STEP 10</b>		
Drain Tube Fitting  x 2	Black Top Cover Screw  x 4	Plastic Canister Insert  x 4	Foam  x 1	

## STEP 1: REMOVE CONTENTS FROM BOX

Remove canister and top cover from the box. Perform a quick inventory to insure all parts are there. If any parts are missing call Pace Edwards Technical Support for replacement, (800) 338-3697.

**CAUTION!** PERMANENT DAMAGE MAY BE CAUSED IF THE HANDLE ASSEMBLY IS ALLOWED TO RETRACT INTO THE CANISTER WITHOUT PROTECTION ON THE UNDERSIDE OF THE FABRIC PANEL!

## STEP 2: PLACE CANISTER

Place the canister in the front of the truck bed, cab side forward, in the position required for unrolling. The canister should be resting on the canister end plates and be centered in the truck bed. Do not attach the canister yet.

### STEP 3: INSTALL & FASTEN THE RAILS

Open the rail box along the length of the box; lift rails out to avoid scratching the rail surface on the package staples. The side rails are marked "left" and "right" (left is the driver's side of the truck). With the tailgate closed, place the side rails in position on the truck bed. Side rails have a rubber spacer on the end caps, at the tailgate end, to establish the correct spacing to the tailgate (1/16") and to prevent the tailgate from striking the side rails when closing. Press the rail tightly against the closed tailgate. Shims may be required to maintain a horizontal top surface on the rails. Peel and stick the shims horizontally close to the rail clamp brackets. Shims are provided in two thicknesses. Shims may need to be stacked on each other to create the right thickness. Repeat the same process on each side.

Place the four (4) clamps over the brackets located on the underside of the rails. Apply downward pressure while tightening the clamps on the rails, especially on the tailgate end. This will ensure a tight seal, firm seat, and good fit on the truck bed. Locate the top groove of the inner clamp bracket onto the lip of the rail bracket (as shown Fig. 4). Rotate the outer clamp bracket clockwise to tighten rail downward against bed rail. Tighten bolt securely. (*Adjust pressure against tailgate by moving rails forward or backward as needed prior to final tightening of clamps.*)

**DO NOT TIGHTEN OVER  
120-INCH POUNDS!**

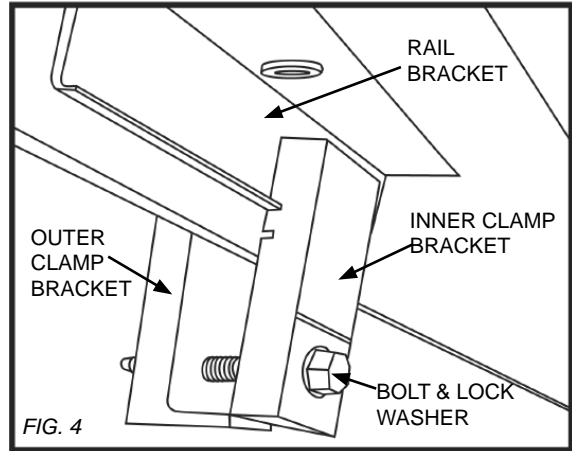

**INSTALL TIP: TO MAKE RAIL INSTALLATION EASIER YOU MAY WANT TO HAVE ANOTHER PERSON HOLD THE RAILS IN PLACE WHILE YOU ARE TIGHTENING THE CLAMPS. YOU CAN ALSO TEMPORARILY TAPE THE RAILS IN PLACE WHILE TIGHTENING THE CLAMPS IF ANOTHER PERSON IS NOT AVAILABLE.**

### STEP 4: INSTALL GUIDE STRIPS

Install the guide strips in the side rails. Be sure the "left" and "right" guide strips are installed on the correct sides. Loosely screw the guide strips to the side rails from the bottom with the #8 machine screws provided (Do not tighten yet).

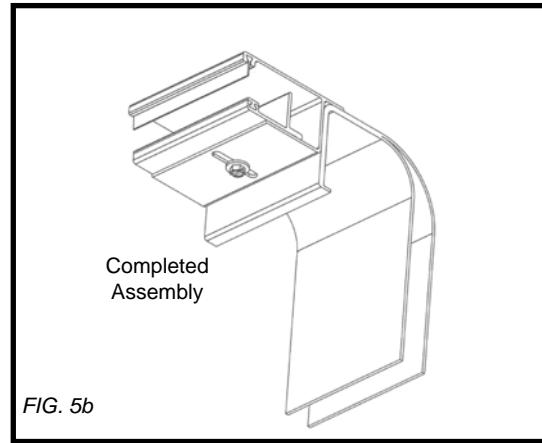
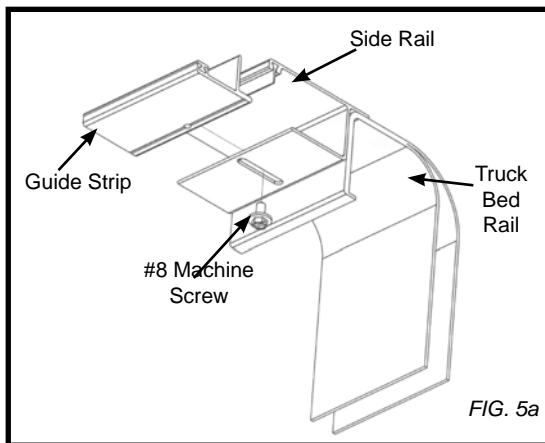

### STEP 5: FASTEN CANISTER

Slide canister against the cab side of the bed. Center the canister side-to-side on the truck bed and fasten it in place with the canister clamps. Use one clamp per side of canister. Install 1/4" - 20 bolt with fender washer through one of the slots in each end of the canister and attach the Canister Clamp. (Fig. 6)

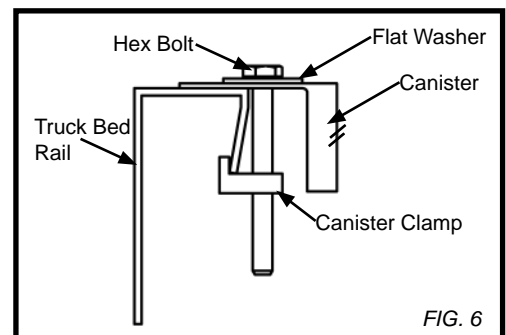

## STEP 6: LUBRICATING & PLACING THE SWEEP SEALS

Locate the sweep seals (rubber weather strips) on the rails. Apply Pace Edwards' UV Protectant (or suitable lubricant) to a rag and wipe the underside of the sweep seal and the top of the wear strip. (Fig. 9)

Use a soft rag or some packing materials from the box to wedge between the fabric roll and handle to temporarily keep the fabric roll from winding into the canister. Carefully remove the ZIP tie securing the cover to the canister we recommend using the wire cutters for this. Roll the handle down into the side rails and down to the tailgate end of the truck bed. Using an Allen wrench if needed to carefully draw out the sweep seal (seal should be angled outwards toward the cover – not rolled in toward the bed rail) (Fig. 9). Proper care and placement of the sweep seal will ensure smooth operation of the cover. Remove the protective foam cover from the underside of the fabric panel. **DO NOT ALLOW THE HANDLE TO ROLL INTO THE CANISTER AS PERMANENT DAMAGE MAY OCCUR TO THE FABRIC.**

***CAUTION!*** PERMANENT DAMAGE MAY BE CAUSED IF THE HANDLE ASSEMBLY IS ALLOWED TO RETRACT INTO THE CANISTER WITHOUT PROTECTION ON THE UNDERSIDE OF THE FABRIC PANEL!

***! YOU MUST PROTECT THE FABRIC FROM THE LOCK ASSEMBLY!***

***! DO NOT BEND THE COVER BACKWARDS AGAINST THE ROLL UP DIRECTION AS IRREPARABLE DAMAGE MAY RESULT!***

## STEP 7: INSTALL LOCK ARM ASSEMBLY

Install the lock arm assembly by sliding the black plastic blocks into the lengthwise groove on the underside of the handle.(Figure 7a & 7b)

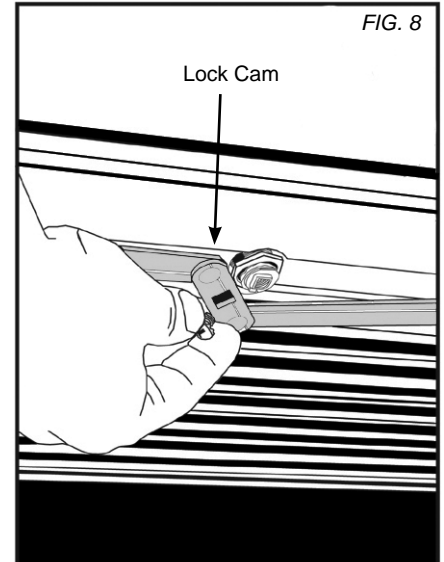
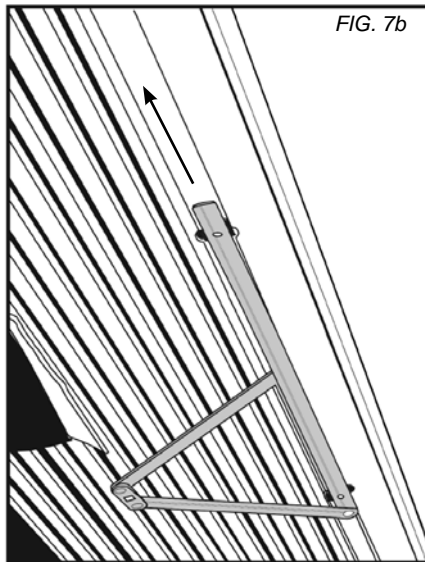
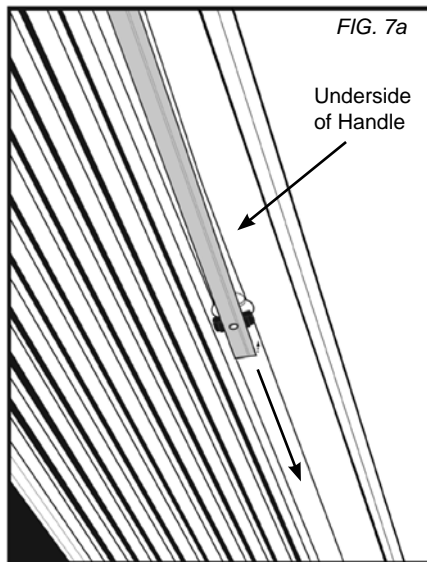

Remove the lock nut from the lock and insert the lock through the lock cover and the center hole in the handle. Install and securely tighten the lock nut with the 7/8" socket until the lock pulls into the fabric and meets resistance to turning. Attach the lock cam of the arm assembly to the lock by engaging the square hole with the square lug on the lock. (Figure 8) Install and tighten the screw. Test to see that turning the key moves the arms in and out. If not, remove the screw and rotate the lock cam 90 degrees and refasten.

## STEP 8: ADJUST POSITIONING OF GUIDE STRIPS

Allow the cover to retract to the first guide strip screws (nearest the canister). Align the vertical portion of the guide strip with the cover assembly leaving 1/8" (3mm) clearance between the two. (Figure 9) This will allow for heat expansion of the aluminum panels on the cover. Tighten the first (nearest canister) guide strip screws on both sides. Next, pull the handle to the guide strip screws nearest the tailgate, align with 1/8" (3mm) clearance on either side and tighten these screws. Close the tailgate and the cover. Make sure that the seal in the handle is making contact along the entire length of the tailgate. If it is not this means the truck bed is not square. Compensate for this by adjusting the guide strips left or right.

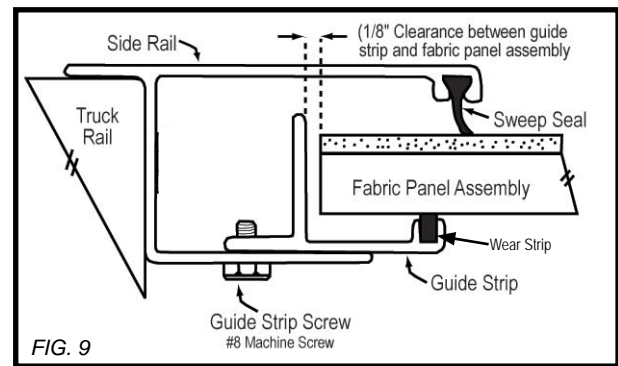

Test again to make sure there is 1/8" clearance on either side of the cover. Retract the cover back towards the canister and tighten the remaining guide strip screws. Check again to make sure that the cover moves in and out freely without binding. (If not, readjust accordingly.)

## STEP 9: ADJUST LOCK ARM (if necessary)

Check the lock function. If the rails were installed correctly, the handle will fit against the tailgate snugly. If the fit is too loose or too tight, there is an adjustment you can do to correct this. The lock arms enter a plastic receiver in the guide strips. The receivers are adjustable to fine-tune the fit to the tailgate. To adjust the receivers, lock your cover at the 18" forward lock position. Look into the rail opening by the tailgate. There are two small Phillips screw heads showing. Loosen them slightly on both sides. Unlock the cover and relock it at the tailgate. Pull the handle back firmly on both sides until a snug fit against the tailgate is achieved. Hold the cover in this position and unlock it. Move the cover back to the 18" lock position. Tighten the Phillips screws.

## STEP 10: INSTALL DRAIN TUBES

With the cover *closed*, insert the drain tube fittings into the pre-drilled holes on the underside of the canister by popping them in place from the inside of the canister. With the cover *open*, place the drain tubes onto the tube fittings. Place the other end of the drain tube through your grommet in the truck bed or through the pre-drilled holes in the floor on the front wall of your bed.

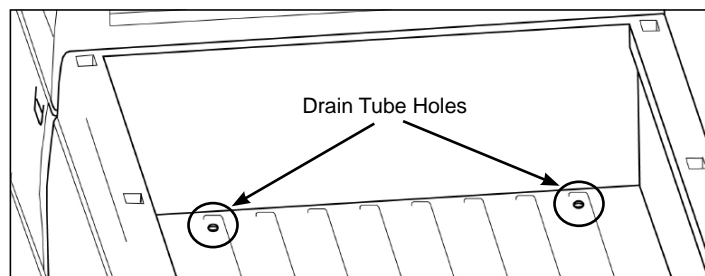

FIG. 10

**INSTALL TIP:** TO MAKE THE DRAIN TUBE INSTALLATION EASIER YOU MAY WANT TO HAVE ANOTHER PERSON HOLD THE TUBE FITTINGS IN PLACE WHILE YOU ATTACH THE DRAIN TUBES TO THEM FROM UNDERNEATH THE CANISTER.

## STEP 11: INSTALL TOP COVER

Insert the plastic canister inserts into the square holes located on either side of the canister. Install the canister top cover with the four long Top Cover screws. Tighten the screws until the cover is just touching the truck bed. Be sure the high side showing the Roll-Top-Cover® label faces the tailgate. **Do not over tighten.** Foam is provided to close up the front of the top cover if needed.

---

## WARRANTY STATEMENT

Pace Edwards Company prides itself in fast, friendly warranty service for all of our products. Our goal is to design quality into everything we make. Pace Edwards' BedLocker®, JackRabbit™, and Roll-Top-Cover® retractable hard tonneau covers offer security, durability, style and convenience unmatched in the marketplace. Our ToolTop™ crossover toolboxes integrate with all three of our retractable tonneau covers, providing the ultimate solution for those who want the security of a toolbox combined with a retractable tonneau cover. Both lightweight and durable, Pace Edwards' Shelf-It™, Rifle-It™, Deluxe Shelf-It™ and Visor Shelf-It™ line of overhead storage solutions provide options for storing items neatly above the sun visors in your vehicle. Other Pace Edwards' warranted products include the PowerGate™ electric tailgate lock and DesignerDash™ dash overlay kits.

We warrant our products to be free from defects in material and workmanship under normal use for **one year from the date of purchase**. In the event of defect in materials or workmanship, we will warrant parts only at no charge, which in our judgment show evidence of such defect within one year from date of purchase.

This warranty is void if the product has direct or indirect damage resulting from accident, misuse or abuse, lack of reasonable care, modifications, alterations, loss of parts, normal wear and tear, acts of god, improper installation or damage during shipping. This warranty does not cover installations on commercial vehicles or to trucks used for racing or off-road. This warranty is void when service or repair is performed by a non-approved service center.

At the end of the warranty period, Pace Edwards Company shall be under no further warranty obligation, express or implied. No other warranty or affirmation of fact, written or oral, is authorized or made by Pace Edwards Company and the terms of this warranty constitute the purchaser's sole and exclusive remedy.

This warranty gives the purchaser specific legal rights and the purchaser may also have other rights that may vary from state to state.

### WARRANTY REQUIREMENTS:

- 1) **Original sales receipt**
- 2) **Product returned must be in original packaging**
- 3) **Product Serial Number**
- 4) **Product Model Number**

For your convenience, you may register your warranty claim at Pace Edwards' web site at [www.paceedwards.com](http://www.paceedwards.com). This will help expedite your warranty claim. If you need warranty assistance, please call (800) 338-3697 and one of our technical service reps will be happy to help you. Please have your model and serial numbers and your original sales receipt available when you call.

---

## HELPFUL MAINTENANCE HINTS

To assure quiet, smooth operation, apply a small amount of grease to the guide strips where the metal end of the panels and the guide strips meet. This initial application should be sufficient for a year or more. Regrease the guide strips if the cover begins squeaking during use.

After installation, if the cover is tight or hard to open and close, the shimming in Step 7 may need to be redone. Over a period of time, if the cover becomes difficult to move in or out (particularly on hot days), check that the side-to-side clearance on the Roll-Top-Cover® is set at 1/8" or more.

Drain tubes may become clogged over time and should be removed and cleaned. Periodically remove the top cover and clean out the canister. To help keep the Roll-Top-Cover® retractable tonneau cover looking its best, we recommend washing it the same as caring for your truck finish. If you have any questions please call our Technical Support at (800) 338-3697.

---

2400 Commercial Blvd, Centralia, WA 98531 USA  
(360) 736-9991 (main) ♦ (360) 736-9992 (fax)  
**(800) 338-3697** (toll-free)  
[www.paceedwards.com](http://www.paceedwards.com)

*Thank you for choosing products by...*

