

# ROLL-TOP-COVER®

RETRACTABLE HARD TONNEAU COVER

## SUPER CREW INSTALLATION INSTRUCTIONS



Roll-Top-Cover® shown on 2002 Ford  
Super Crew



**Pace Edwards Company**  
2400 Commercial Blvd.  
Centralia WA 98531

**(800) 338-3697** toll free  
**(360) 736-9991** main  
**(360) 736-9992** fax

**www.paceedwards.com**

Part #: RT-SC INSTALL 084  
Revised 08/04

### TABLE OF CONTENTS

Tools Required for Assembly .....	2
Before You Start .....	2
Drain Hole Locations (FIG. 1).....	2
Packaging Contents (FIG. 2) .....	2
STEP 1: Remove Contents from Box (FIG. 3 & 4).....	3
STEP 2: Install the Lock Arm Assembly (FIG. 5,6 & 7).....	3
STEP 3: Place the Canister (FIG. 9 & 10).....	3
STEP 4: Install Rails & Guide Strips (FIG. 11-19).....	3
STEP 5: Canister Inserts (FIG. 20).....	3
STEP 6: Adjust Position of Guide Strips (FIG. 21 & 22).....	4
STEP 7: Install Drain Hole Fittings (FIG. 23).....	4
STEP 8: Install Top Cover (FIG. 24 & 25).....	4
STEP 9: Install Drain Tubes .....	4
STEP 10: Check the Lock Function .....	4
Helpful Maintenance Hints .....	4

**TOOLS REQUIRED FOR ASSEMBLY:** Electric drill, phillips screwdriver, slotted screwdriver (or 5/16" nut driver), 10mm metric combination wrench, and a #6 torx driver. **NO CUTTING IS REQUIRED.**



**BEFORE YOU START:** Read the instructions carefully before you start. If you have questions regarding the installation of your new Roll Top Cover®, please call our Tech Support Line at 1-800-338-3697 or visit our web site at [www.paceedwards.com](http://www.paceedwards.com). The Roll-Top-Cover® is designed to carry rainwater from the fabric cover into the canister and then drain out through drain tubes to the street. In order to install the drain tubes, the size of the two outer drain holes located in the forward part of the bed of your Super Crew must be increased. Before drilling, be sure to check the underside of the truck bed for the best location. The holes should be located near the side and as far forward as practical. Use a drill bit suitable for sheet metal (such as a taper drill or step drill). Drill drain tube clearance holes 5/8 inches (16mm). (Figure 1)

**NOTE:** Refer to the Parts List for complete item names and listing.

**A. CONTENTS IN CANISTER CARTON** (Figure 2)

- 1. One Top Cover Assembly (covers canister) Item "A"
- 2. One Canister Assembly Item "C"
- 3. Lock Arm Assembly Item "F"
- 4. One Screw Pack, Lock and Keys (in styrofoam packing)
- 5. One Shim Pack
- 6. Top Cover Screws (4) & Side Rail Screws (10)
- 7. One Foam Strip
- 8. Two Drain Tubes (not shown in fig. 2)

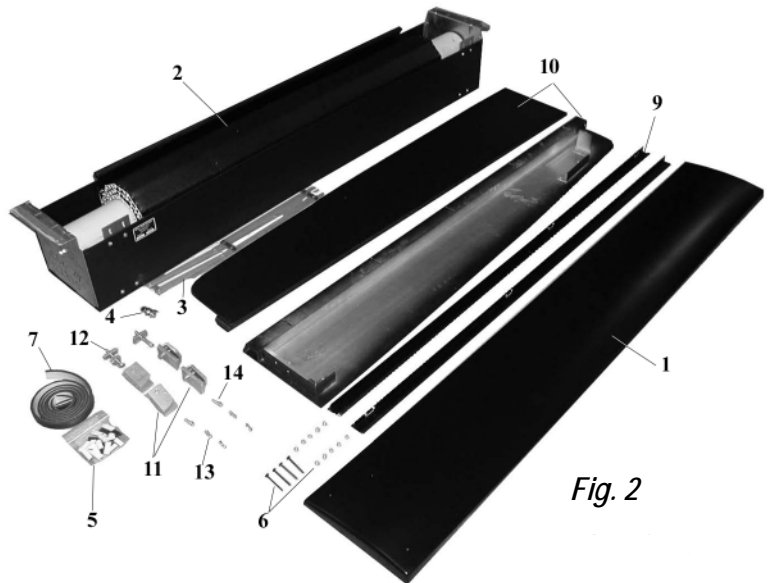

**B. CONTENTS IN RAIL CARTON**

- 9. Two Guide Strips, one left and one right
- 10. Two Rails, one left and one right
- 11. Four Rail Clamps
- 12. Two Canister Clamps, one left and one right
- 13. Clamp Bolts Sets (includes lock, star, and flat washer)
- 14. Tek Screws (2)



**STEP 1:**

Remove the Top Cover Assembly from the canister and set aside for later assembly. Remove the canister from the shipping carton. Before placing the canister in the truck bed, remove the screw and metal clip that is holding the handle to the canister for shipping purposes. (Figure 3) Use a soft rag or the packing material from the shipping carton to wedge between the fabric roll and the handle to temporarily keep the fabric roll from winding into the canister and protect the fabric from the lock after it is installed.

**WARNING!** Always protect the exposed fabric cover from the protruding lock cylinder with adequate padding. Irreparable damage will occur if the handle is allowed to roll up onto the fabric with the lock installed. (Figure 4)

**STEP 2:**

Install the Lock Arm Assembly (item F) by inserting the black plastic blocks into the underside of the handle. (Figure 5) The handle is attached to the outboard end of the fabric panel assembly. This is done via the center opening in the handle. The Lock Arms will extend equally beyond the handle to provide locking. Remove the nut from the lock and insert the lock through the handle (Figure 6) but **DO NOT BEND THE COVER BACKWORKS AGAINST THE ROLL-UP DIRECTION, AS IRREPARABLE DAMAGE MAY RESULT.** Install and tighten the nut until the lock pulls into the fabric and meets resistance to turning.

Attach the CAM of the Lock Arm Assembly to the lock by engaging the square hole with the square lug on the lock. Install and tighten the screw. Test to see that turning the key moves the arms in and out. If it doesn't, remove the screw and rotate the lock CAM 90 degrees and refasten.



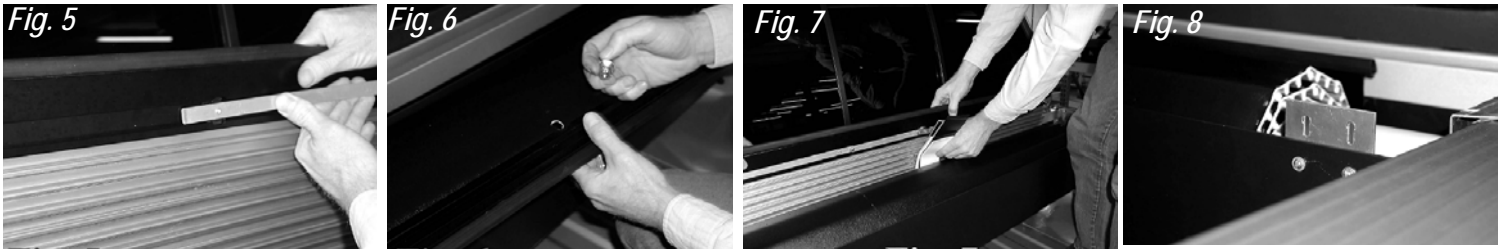

When this is complete, allow the handle to return to the canister, making sure to **PROTECT THE FABRIC FROM THE PROTRUDING UNDERSIDE OF THE LOCK** until the cover is fully assembled and in the side rails. (Figure 7) Attach the rail plate to the inside of the canister. (Figure 8)

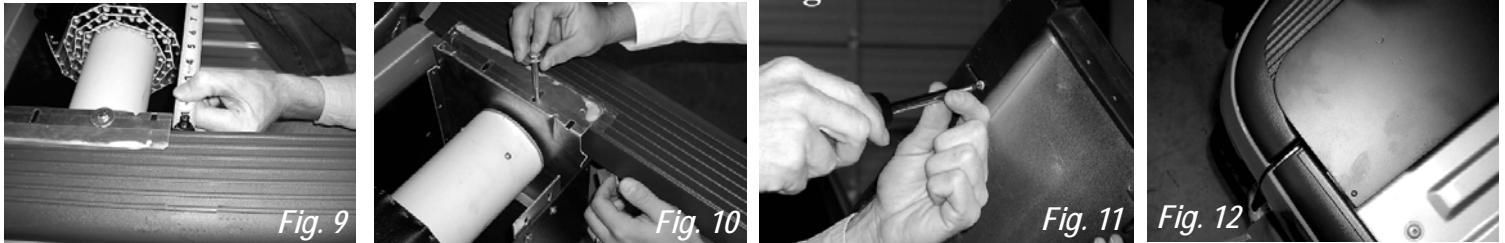

**STEP 2:**  
Place the canister on the truck sill against the front of the bed, cab side forward, in the position required for unrolling. Center the canister between the truck side rails (Figure 9) and install the canister clamps with the bolts provided (Figure 10). **NOTE: DO NOT OVER TIGHTEN THE CANISTER CLAMPS.**

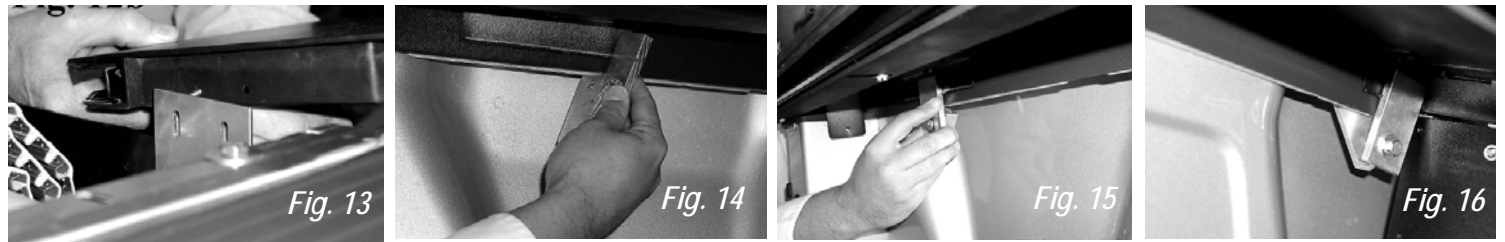

**STEP 3:**  
Remove the **SIDE RAILS** (item 10) and **GUIDE STRIPS** (item 9) from their carton and use them to check the sides of the truck bed for squareness to the rails. Install the **GUIDE STRIP** in the Side Rail. Be sure the "Left" and "Right" Guide Strips are installed on the corresponding left and right rails. Screw the Guide Strip to the Side Rail "finger tight" from the bottom with the #8 machine screws provided but **DO NOT TIGHTEN THEM YET** (see Figure 11 for screw locations). With the tailgate closed, place the Side Rails in position on the truck. The Side Rails are marked "left" and "right" (left is the driver's side of the truck). Locate the rails to allow 1/16" clearance at the tailgate end to prevent tailgate movement from striking the Side Rails when closing the tailgate (Figure 12). Attach rails to Canister (Figure 13).

Install clamps so that the slot in the clamp grips the bracket on the rail (Figure 14 & 15). Each clamp has a groove cut in it that should grip the rail so that when it is bolted down, it is held firmly in place. (Figure 16) **NOTE: THE RAIL WILL BE LIFTED SLIGHTLY AT THE CANISTER, WHEN THE CANISTER IS INSTALLED THIS WILL COME DOWN. THIS IS DUE TO THE CURVE IN THE SIDE RAIL OF YOUR SUPER CREW.**



Install rubber spacer with #10 x 1 1/2" tek screw through the bracket at the back of the rail (Figure 17 & 18). Hold rail down tight against the truck while installing screw (Figure 19).

**STEP 4:**  
Insert the plastic canister inserts (Figure 20) into the square holes located on either side of the canister. These will later be used for mounting the top cover assembly (Item #A).

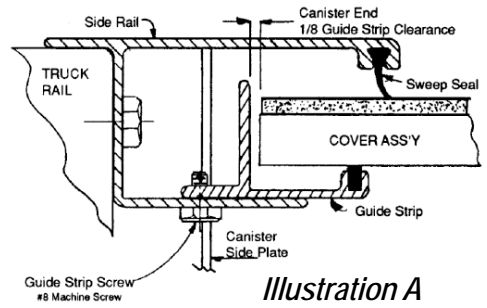
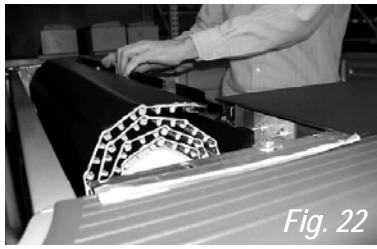

**STEP 5:**

Unroll the cover, remove the pad protecting fabric (Figure 21) and pull the handle into the side rails *taking care not to scar the cover with the lock assembly that protrudes through the handle (Figure 22)*. Pull the cover back and lock it to the tailgate end.

**WARNING! DO NOT ALLOW THE COVER TO ROLL UP UNTIL THE TOP COVER ASSEMBLY IS SECURLY INSTALLED OR THE COVER WILL ROLL ONTO ITSELF AND COULD CAUSE PERMANENT DAMAGE.**

Open the tailgate and center the handle left and right between the guide strips, leaving 1/4" (6mm) side-to-side clearance (1/8" on each side) to allow for heat expansion of the aluminum panels on the cover. Tighten the guide strip screws nearest the tailgate (Illustration A). Close the tailgate AND BE SURE THE SEAL IN THE HANDLE IS MAKING CONTACT ALONG THE ENTIRE LENGTH OF THE TAILGATE. If it is not, the truck bed is not square. Compensate for this by relocating the guide strips left or right. Test again to make sure there is about 1/4" side-to-side movement in the cover. This clearance is necessary to compensate for temperature variations causing expansion and contraction of the cover. Tighten the guide strip screws nearest the tailgate. Then retract the cover back toward the canister and systematically tighten the guide strip screws. Check again to be sure the cover moves in and out freely without binding or without excessive side-to-side movement (if not, re-adjust accordingly).



**STEP 6:**

With the cover locked at the tailgate, install the two aluminum DRAIN FITTINGS in the canister floor, pushing them down firmly and evenly until they seat against the bottom of the canister (Figure 23).



**STEP 7:**

Install the canister TOP COVER with the four long stainless steel sheet metal screws (Figure 24). Tighten the screws until the cover pulls the side rail into position, level with the truck bed rail. DO NOT OVER TIGHTEN. This also assures that the handle has a positive stop position without retracting into the canister. Be sure the high side showing the Roll-Top label faces the tailgate. The foam strip provided may be used to obtain a tighter seal between the front sill of your Super Crew and the Top Cover Assembly. (Figure 25)

**STEP 8:**

Roll the cover into the canister. Slip the PLASTIC TUBES onto the drain hole fittings from the underside of the canister and down through the holes in your truck bed which you drilled "before you started".

**STEP 9:**

Check the lock function. If the rails were accurately installed, the handle will fit against the tailgate lightly. If the fit is too loose or too tight, there is an adjustment to correct this. The lock arms enter a plastic receiver in the guide strips. The receivers are adjustable to fine-tune the fit to the tailgate. To adjust the receivers, lock your cover at the 18" lock position and look at the inside of the rail and guide strip assembly at the tailgate. There you will see a plastic lock arm receiver and two Phillips head screws, loosen these screws but do not take them out. With a flat head screwdriver adjust the lock receiver to the position needed to obtain the desired seal at the tailgate. Tighten the two screws, repeat on the other side and test.

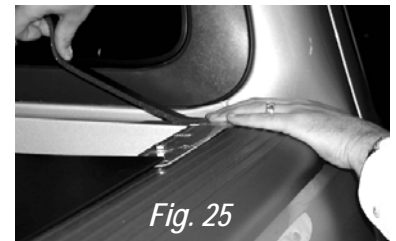

Now you have completed the installation of your Roll-Top-Cover® for your new Ford F150 Super Crew. With proper care and maintenance you should enjoy dependable service from your Pace Edwards Roll-Top-Cover.

To assure quiet, smooth operation, apply a small amount of grease to the wear strips where the metal end of the panels and the wear strips meet. This initial application should be sufficient for a year or more. Regrease the wear strips if the cover begins squeaking during use.

It is important to open and close the cover regularly; the spring that operates the cover is self-lubricated and regular use assures that it stays in proper working condition.

Drain tubes may become clogged over time and should be removed and cleaned. Periodically remove the top cover and clean out the canister.

To help keep the Roll-Top-Cover retractable tonneau cover looking its best, we recommend washing it the same as caring for your truck finish. However you should not wax your cover. Using a citrus based vinyl cleaner and protectant such as Pace Edwards Brand or the 303 brand will keep your cover looking like new. Alcohol, petroleum based or silicon-based cleaners such as Armor-All should be avoided and ARE NOT recommended for our covers.