

INSTALLATION SHEET

ENCORE TONNO

extang
AMERICA'S BEST
SELLING TONNEAUS

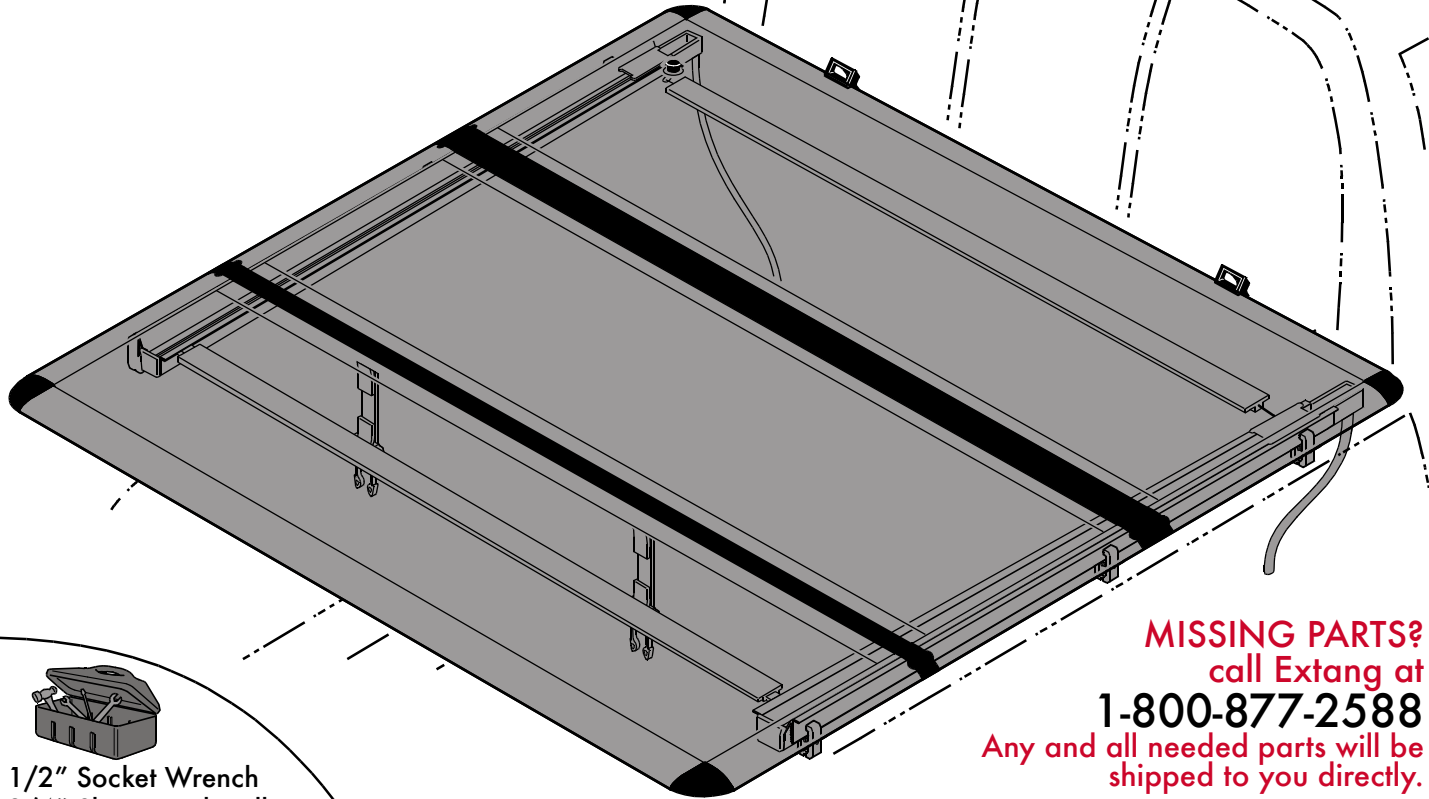

- 1/2" Socket Wrench
- 3/4" Sheetmetal Drill Bit

MISSING PARTS?
call Extang at
1-800-877-2588
Any and all needed parts will be
shipped to you directly.
(DO NOT return whole kit to store)

- 1** Place the underbody rails along the top edge of the side wall. Rail should be one inch back from the cab rail sheetmetal edge. (Note: if truck has a bedliner, the distance will be smaller.) Rails **must** be installed level to ensure smooth operation and latch engagement. This may require moving the clamps up or down vertically on rail to achieve level position. Secure with clamps as shown (3 normal, 4 long bed).

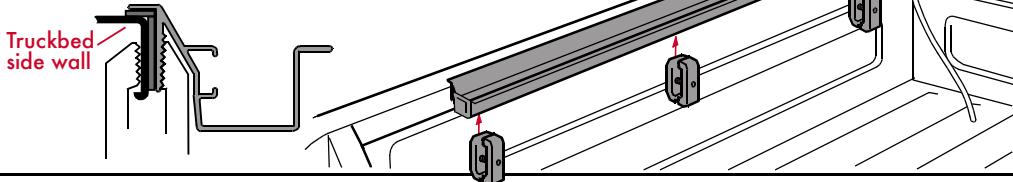

- 2** Drill a 3/4" hole through the truckbed knockout plug, truckbed or bedliner. Insert the drain hose through that hole.

Drill a 3/4" hole through the truckbed knockout plug, truckbed or bedliner. Insert the drain hose through that hole.

- 3** Stand the bundled panel system on the drain rails so that the retaining hooks line up with the two pins inside the drain channel as shown here.



Be careful not to scratch the truck finish at this step!

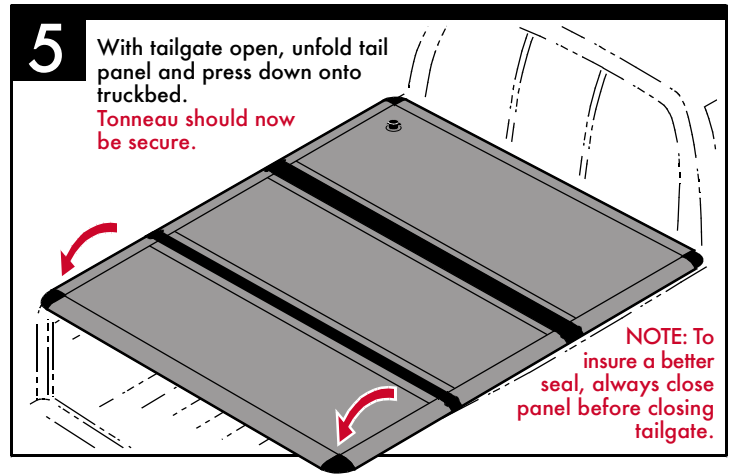
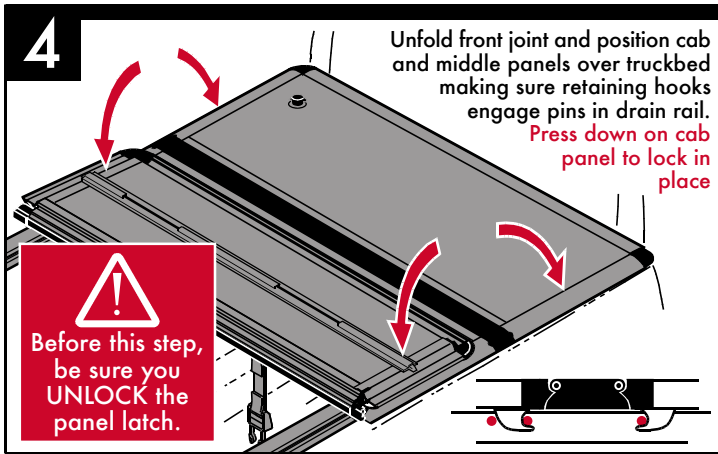

To Open the Cab Panel

To access storage at the front of your truckbed, turn the locking knob on the driver side of the cab panel. Be careful not to drop cab panel on center panel, it may mar panel surface. Always make sure the key is removed and the lock cylinder cover is closed when folding cover. To unlock the knob, lift the lock cover and insert key.

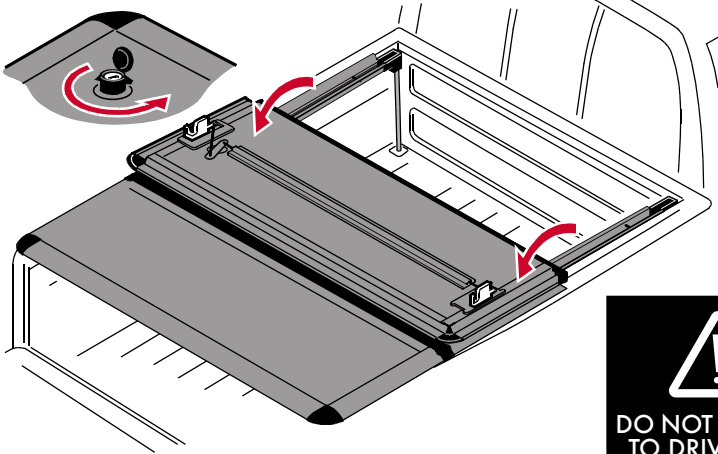

To Open the Tail Panel

To raise the tailgate panel, open the tailgate and reach in to the cable inside the panel housing. Pull down on the cable to release both rear latches.

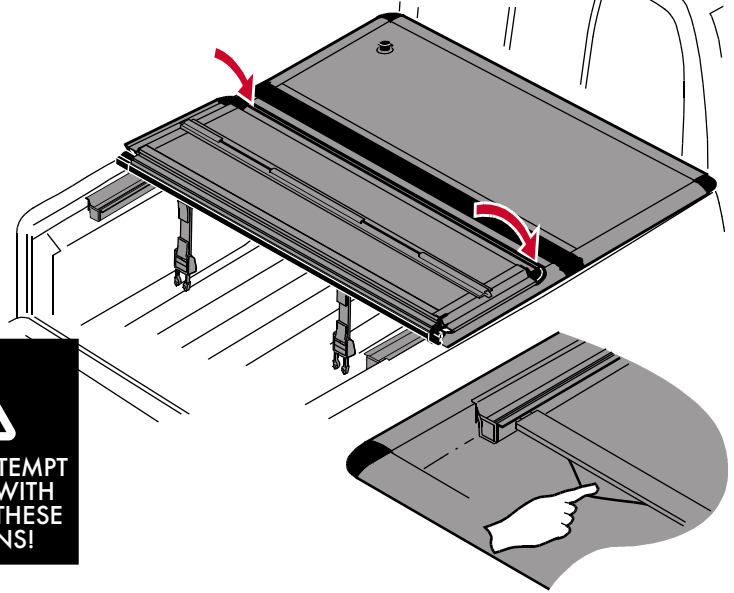

DO NOT ATTEMPT TO DRIVE WITH COVER IN THESE POSITIONS!



Remove any snow or foreign matter before folding cover.

IMPORTANT NOTICE
 While driving, cover must be completely flat and secure with all four latches in the closed position or completely folded up (all panels) and secured at the cab. **DO NOT DRIVE** with cover in partially opened position.

Secure the Encore cover with attached clips. **YOU MAY DRIVE WITH THE COVER IN THIS POSITION.**

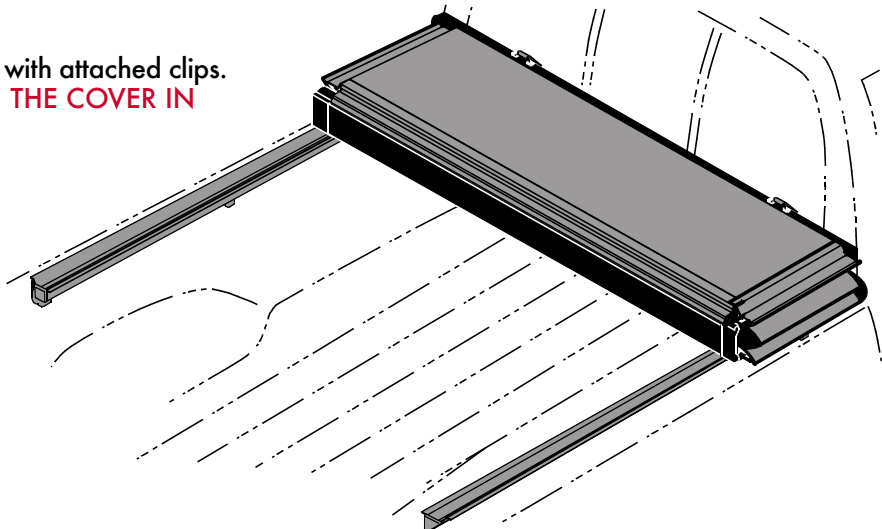

Supplemental Cab Foam Seal

SUPPLEMENT to INSTALLATION INSTRUCTIONS for

Ford F150 & SuperDuty applications

Apply foam seal (included) to front lip of truck bed (below cab rear window) from driver side bed rail cap to passenger side bed rail cap.

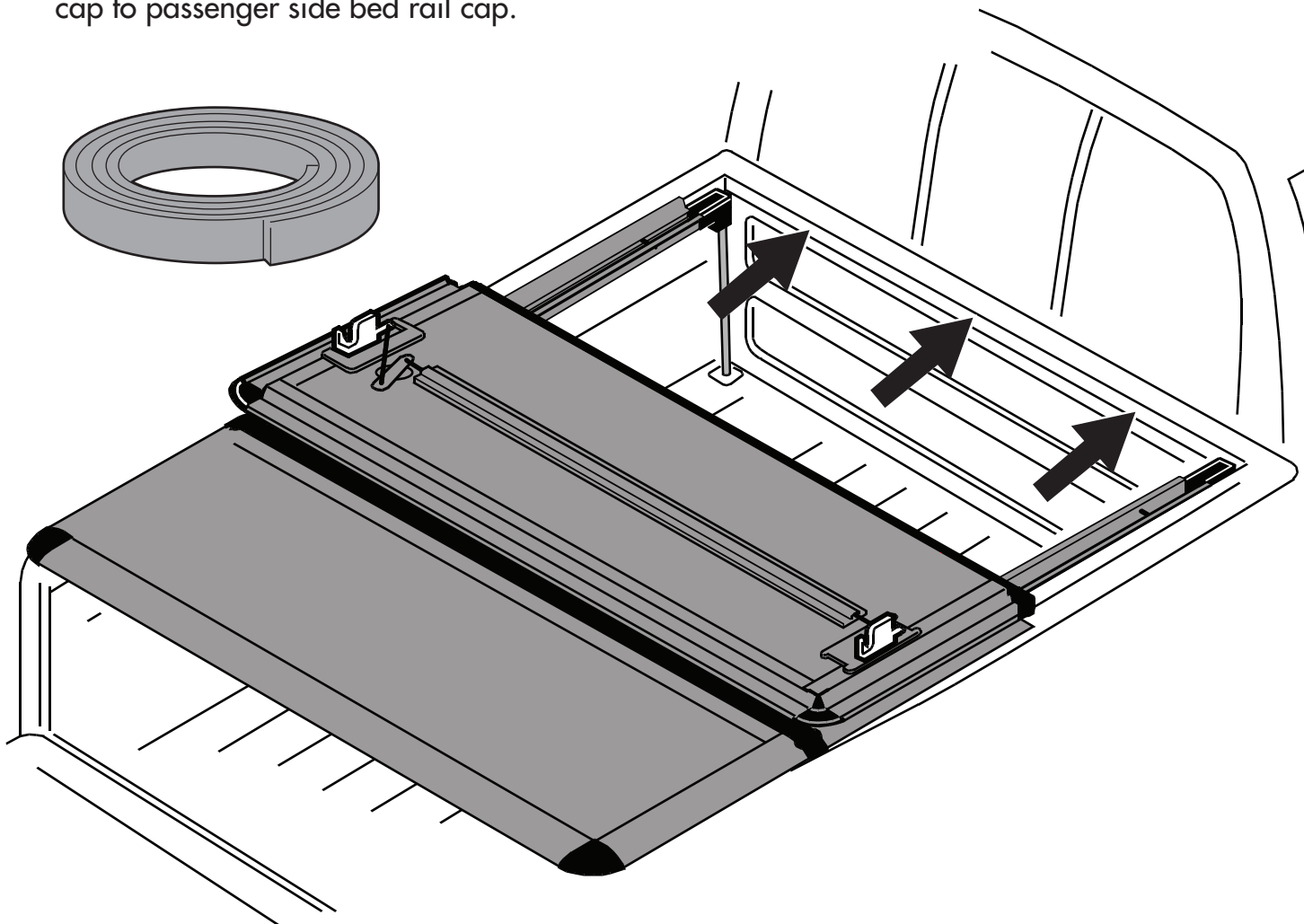

extang
AMERICA'S BEST
SELLING TONNEAUS

Extang Corporation
1901 E. Ellsworth Rd.
Ann Arbor, MI 48108
734 677-0444, Fax: 734 677-8409

Register your warranty at:

www.extang.com

RRE Printed in U.S.A.

MAXIMUM STRENGTH WARRANTY

READ CAREFULLY - KEEP IN A SAFE PLACE

PLEASE ATTACH AND SAVE YOUR SALES RECEIPT.
ACTIVATE YOUR WARRANTY ONLINE AT WWW.EXTANG.COM.

EXTANG LIMITED WARRANTY

SOLID FOLD FOLDING HARD LID TONNEAU

ENCORE TONNO

■ WARRANTY DURATION:

Extang offers three years of coverage from the date of purchase. Warranty is limited to original purchaser of truck bed cover and is non transferable.

■ WARRANTY CONDITIONS:

This warranty is against defective materials or workmanship. The warranty is void if the product has been damaged by accident, unreasonable use, neglect improper service/installation/removal, modifications, acts of God, normal wear and tear or other causes not arising out of defective materials or workmanship. Consequential and incidental damages are not covered under this warranty.

WARRANTY EXCLUSION:

- Warranty is void if defect in materials and workmanship is not reported in writing within 30 days of discovering a defect.
- Warranty does not cover the cost of shipping, including the cost of returning the product for warranty service or inspection.
- Warranty does not cover scratches and dents to bed cover. Warranty further excludes damage to bed cover as a result of placing, storing, or hauling objects on top of bed cover.
- Warranty will be void if shipping damage is not reported in writing within 3 business days of purchase.

■ PERFORMANCE:

Provided all warranty conditions are met Extang will either repair or replace (at Extang's option) the product or component. Extang may require the original item to be returned postage prepaid for final determination. Extang reserves the right to substitute and offer the respective warranty discount on an entire replacement system or provide other remedies than those listed in this warranty for discontinued products or other reasons. A return authorization number must be obtained from our customer service department prior to returning any product. **Shipping charges will apply for any repair or replacement.** This warranty gives you specific legal rights and you may also have other legal rights which vary from state to state.



HELPFUL ACCESSORIES

MAXSEAL TAILGATE SEAL



The MaxSeal Tailgate Seal creates a tight seal along sides and bottom of your tailgate to keep out dust, rain and snow. MaxSeal is quick and easy to install: just cut, peel and stick. It's made of all-weather grade, UV, gas, and oil resistant rubber. The universal length fits all makes & models.

List Price \$29.95

B-light TONNEAU LIGHTING SYSTEM



Illuminate the entire bed with one control switch. The B-Light is totally compatible with all makes/models of pickup trucks. The B-Light kit contain 8 high intensity LED units with six bulbs each. Plenty of power to shine light in every corner of the bed. The strategic under rail bed placement keeps the lights well protected from shifting cargo.

List Price \$99.33

Order today, direct from our customer service department:

1-800-877-2588

1901 EAST ELLSWORTH, ANN ARBOR, MI 48108
VOICE: 734-677-0444 or 1-800-877-2588
FAX: 734-677-8409 EMAIL: info@extang.com
WEB SITE: www.extang.com

