

INSTALLATION SHEET GMC/Chevy Stepside '99-

Part # 7920, 2920

CLASSIC
**PLATINUM &
BLACKMAX™**

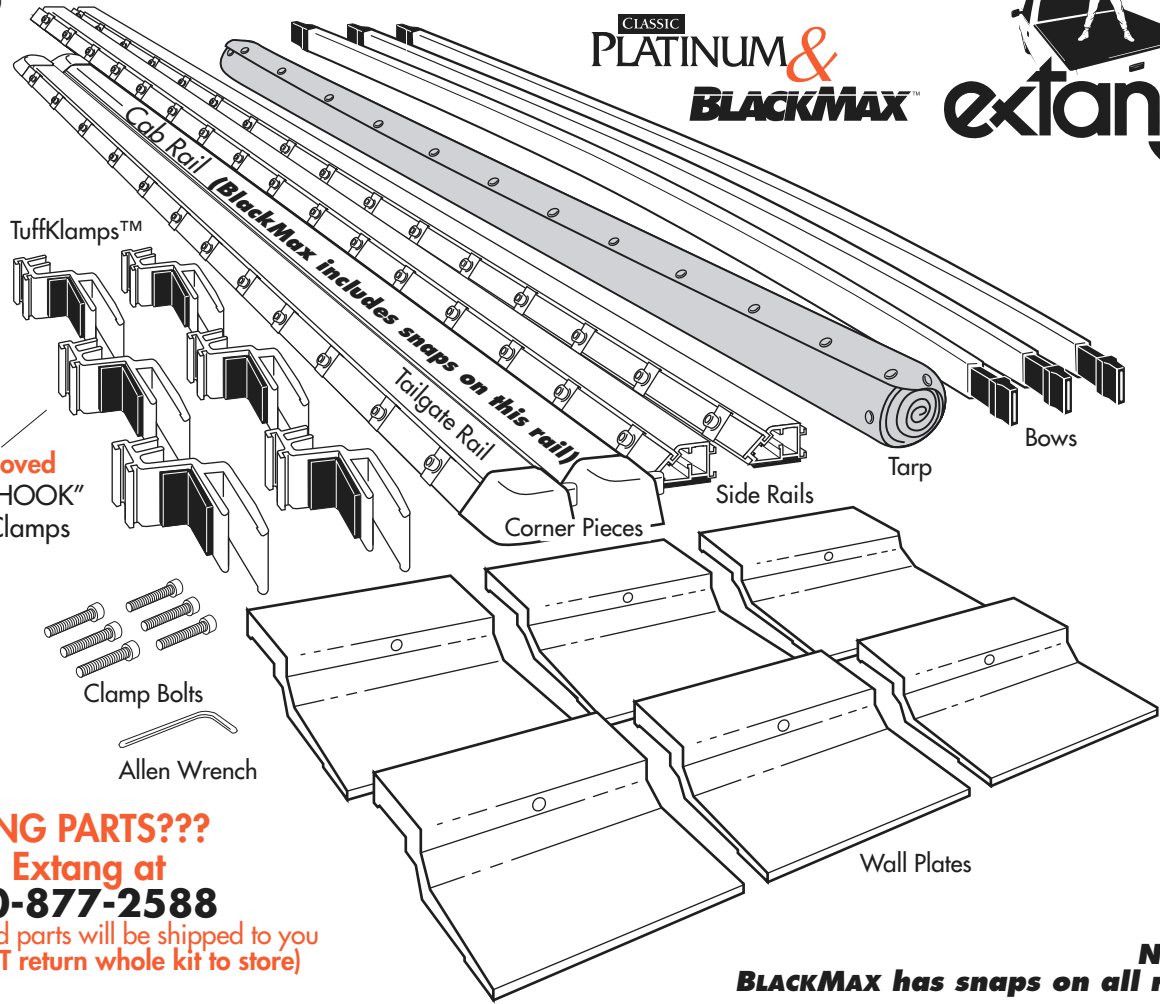

**NEW Improved
"DOUBLE HOOK"
Side Rail Clamps**

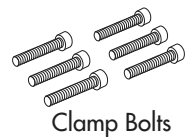

Allen Wrench

MISSING PARTS???
call Extang at
1-800-877-2588

Any and all needed parts will be shipped to you directly. (DO NOT return whole kit to store)

NOTE:
BLACKMAX has snaps on all rails.

PARTS INCLUDED IN YOUR KIT. You may want to lay them out in this manner for accessibility.

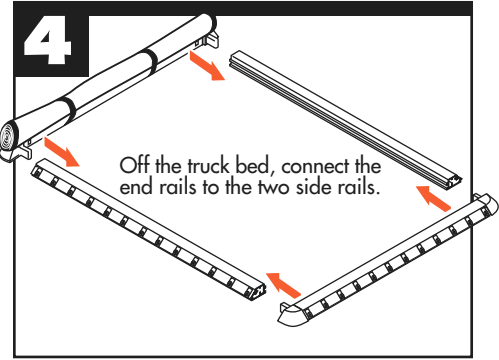
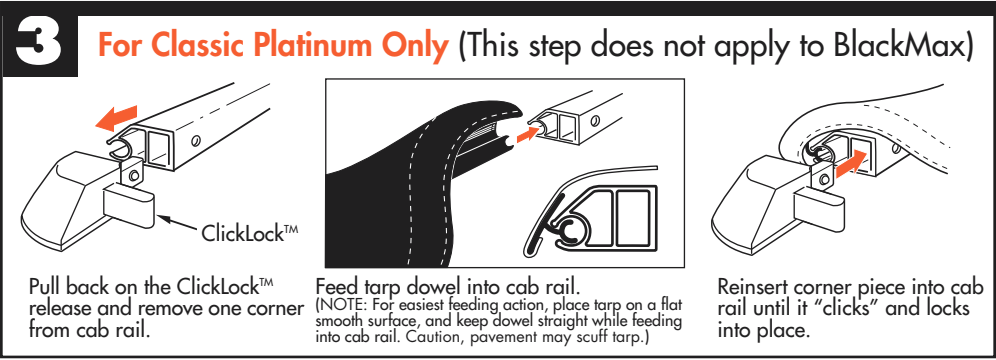
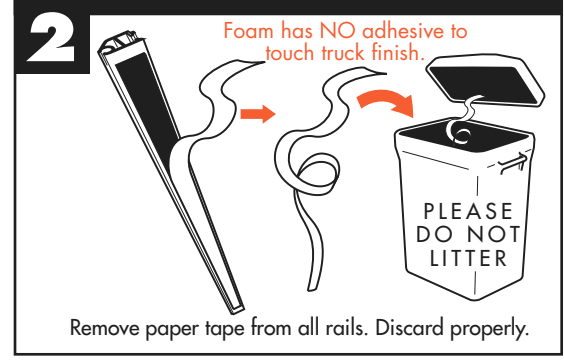
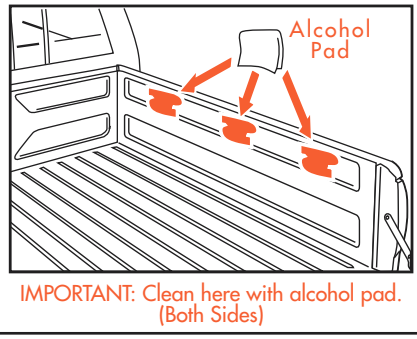
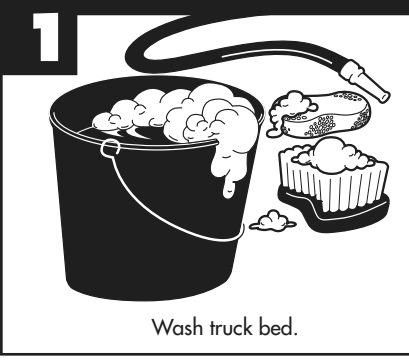

5

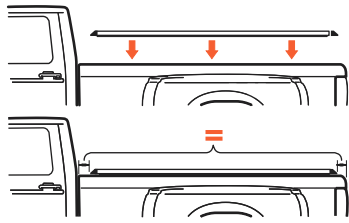

Place the rail assembly over the side of the truck box. Center rails evenly between cab and tailgate. (NOTE: Some applications have hard rubber risers (square rubber pad.) A riser must go toward tailgate. Some applications will have a riser at both ends, (most have no riser).

When positioning wall plates be sure that they fit correctly against the truck bed wall. The plates must seat against the bottom of, and parallel to, the wall indentation.

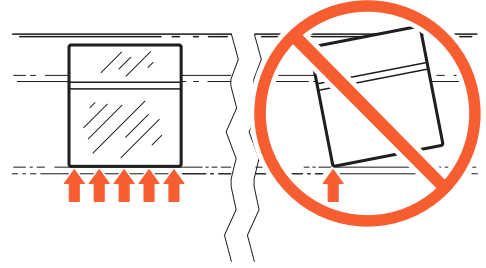
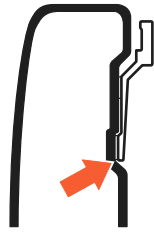

Note: For over-the-rail bed liners first refer to Diagrams A and B below.

6

Clamp Spacing (Same for each side)

See the stickers located on each side rail for clamp position, or refer to the dimensions given below. Note: Remove stickers after installation.

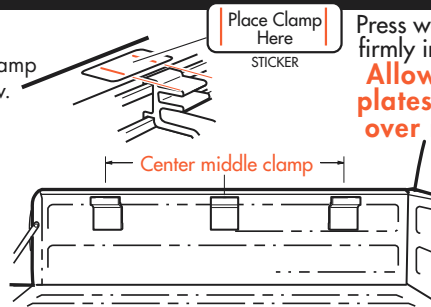
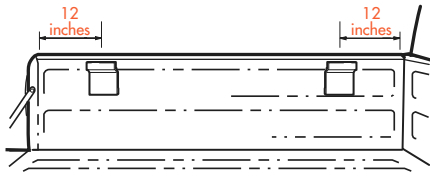

Press wall plate firmly in place. Allow wall plates to set over night.

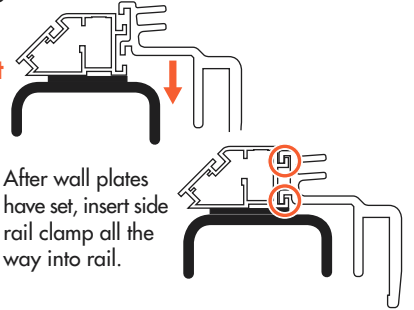

Note: Measure all distances from screw hole centers.

7

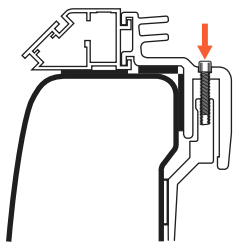

Insert clamp bolt in place. Do Not Overtighten

8

Insert bow onto top or bottom peg. (Top peg for performance, Bottom for good looks.)

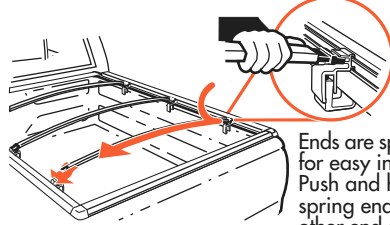

Ends are spring loaded for easy installation. Push and hold on spring end and let the other end slide on with the spring action.

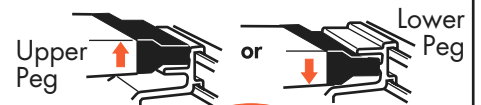

SPECIAL FEATURE: Two pegs offer two height adjustments.

Note: Bow End does not fit between pegs.



9

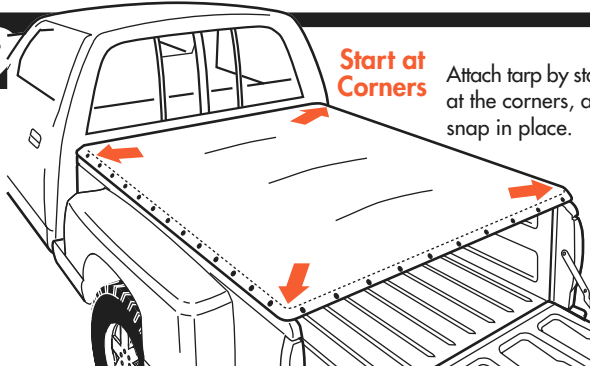

Start at Corners Attach tarp by starting at the corners, and snap in place.

SPECIAL FEATURE Weather-adjustable Snaps

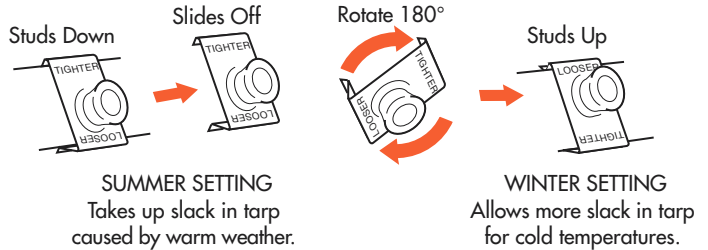

For an OVER-THE-RAIL Bedliner

DIAGRAM A

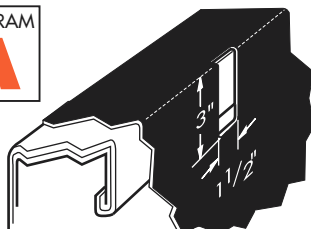

For each clamp mark on your bedliner a 1-1/2" x 3" hole as shown above. Remove clamp. Cut holes in bedliner. Reinsert side rail clamp. Return to step 6.

DIAGRAM B

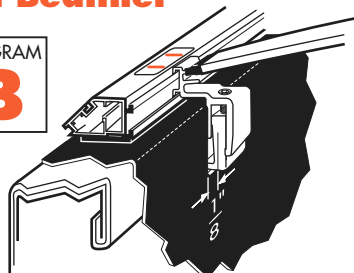

Side rail clamped to bed with bow attached.

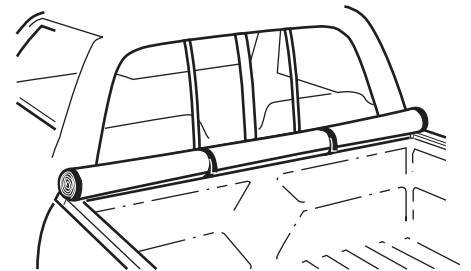

EASY USE OF TRUCK BED

Tarp may be rolled up and secured with Velcro® for bulk hauling