



Remote Mount Solenoid Pack

PN 2302283

EP 6.0 and EP 9.0 Winches

INSTALLATION • OPERATION • SAFETY PRECAUTIONS

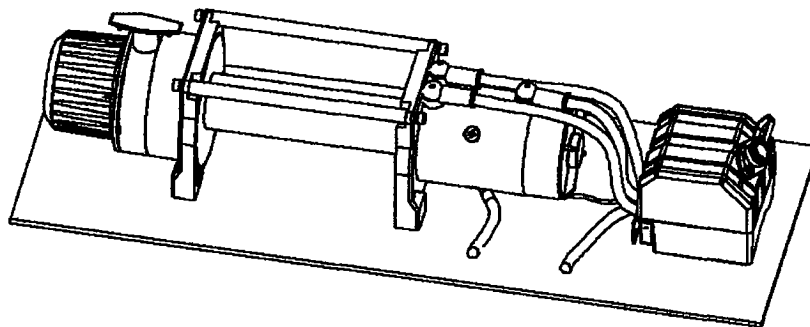

CAUTION

Read instructions completely before beginning.

Contents

1	Lead Wire, Motor Armature
1	Lead Wire, Motor Field 2
1	Lead Wire, Motor Field 1
1	Lead Wire, Solenoid Ground
5	Terminal Boot

Part Number

90-22635-43
90-22635-44
90-22635-45
90-23330-19
90-23247-04

REMOTE MOUNT SOLENOID PACK INSTALLATION

Step (1)

Check to ensure that the vehicle ground and positive leads from the battery are disconnected before performing any electrical work.

DANGER

DO NOT ATTEMPT TO INSTALL WIRING WHEN THE BATTERY IS CONNECTED.
Automotive batteries contain flammable and explosive gases. Wear eye protection during installation and remove all metal jewelry. Do not lean over battery while making connections.

90-17397 rev - 10/14/04

Step (2)

To remote mount the solenoid pack the unit must be disassembled from the winch. Review the solenoid pack assembly shown in fig 1.

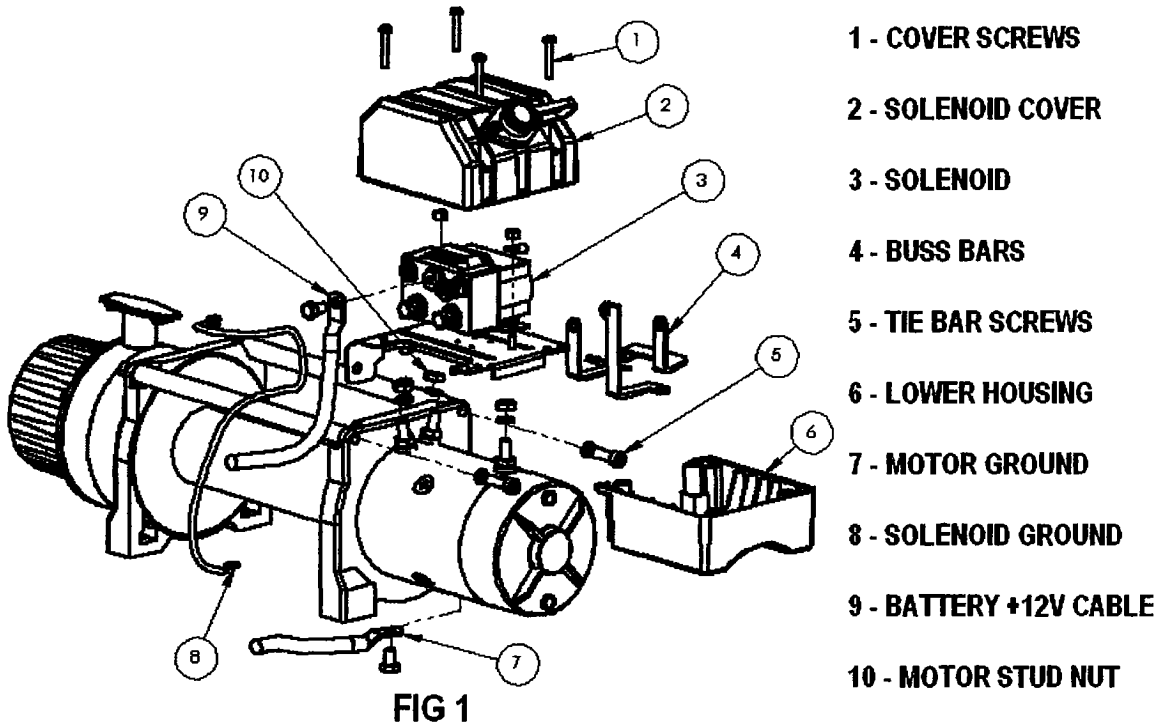

Step (3)

Remove the 4 screws holding on the cover. Disconnect the three 20 gage wires from the socket by pulling off the quick connects on the solenoid. Remove the bolt holding the 2 gage red battery cable to the solenoid. This bolt also holds the 20 gage red wire from the winch socket. Remove the red 2 gage battery cable by pulling out from the bottom. Remove cover.

Step (4)

Remove the lower housing by carefully spreading open the housing at the drum support end. Slide the lower housing back away from the winch and remove.

Step (5)

Disconnect the buss bars from the solenoid by removing the 3 solenoid bolts. Remove the 10 gage solenoid ground wire by unbolting the motor ground bolt on the bottom of the motor.

Step (6)

Unbolt the solenoid bracket by removing the tie bar screws. Take care removing the tie bar screws to avoid uncoupling the motor from the winch drum. Reassemble the tie bar screws after removing the solenoid bracket.

Step (7)

Remove the buss bars from the motor. Hold the lower lock nut and remove top nut. **Important: Do not allow the motor terminals to rotate; this could cause internal wire breakage.** See fig 5. The buss bars are not used when remote mounting solenoid.

▲ WARNING

Ensure that the wiring harness does not interfere or come in contact with any hot or moving engine, suspension, steering, braking, or exhaust parts.

Step (8)

Find a location to mount the solenoid control pack. Mount the solenoid pack so the 20 inch long lead wires will reach the winch. The solenoid control pack is typically mounted to a horizontal or vertical surface. The solenoid pack can be foot mounted or bulkhead mounted. See fig 2 and fig 3. Foot mounting uses 4 mounting holes in the lower housing. Use (4) 1/4-20 bolts to secure the lower housing to horizontal surface. Bulkhead mounting uses (2) 1/4-20 bolts to secure to vertical surface.

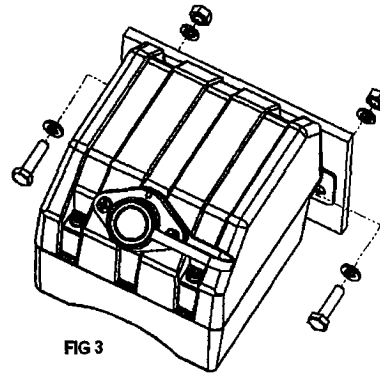
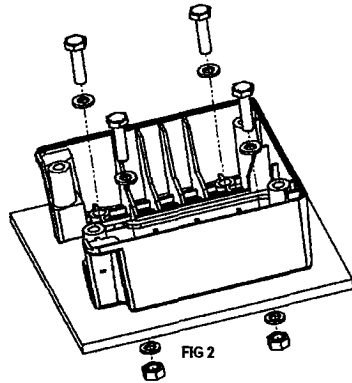

▲ WARNING

Do not mount solenoid pack sideways such that the studs of the solenoid face down. See fig 4. Mounting the control pack with the solenoid studs facing down loads the return springs with the weight of the solenoid armature. With shock and vibration loading this could cause premature spring failure due to fatigue.

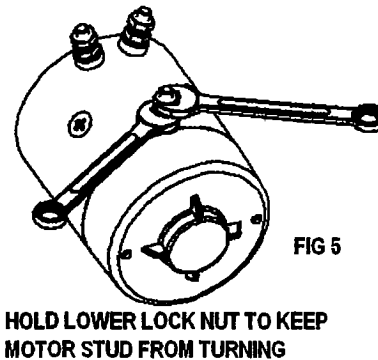
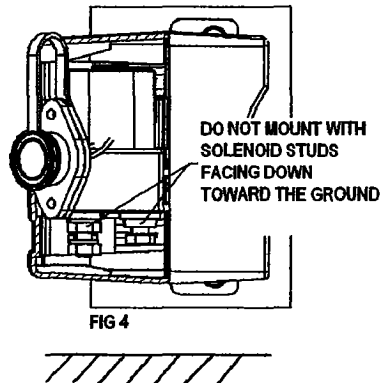

Step (9)

Assemble the three motor 2 gage lead wires to the solenoid. The solenoid, motor and lead wires are color coded. Assemble the 10 gage solenoid ground wire to the solenoid. Attach the battery 2 gage red lead wire and the 20 gage red lead wire from cover socket to the same solenoid bolt. Assemble a terminal boot to the red battery lead and the white armature lead as shown in fig 6. Slide boots on wire before attaching wire terminals to studs. Connect the three socket 20 gage lead wires to the solenoid by plugging in the quick connectors.

Step (10)

Place the solenoid with bracket on the lower housing. Run the solenoid lead wires out the end of the lower housing, under the metal bracket flange. Use cable ties as required to hold lead wires in place. Assemble the cover with the 4 screws. Attach the three 20 inch lead wires to the winch motor. Use terminal boots on all three motor connections. Slide boots on wire before attaching wire terminals to studs. Assemble the 10 gage solenoid ground with the 2 gage motor ground by attaching the bolt on the bottom of the motor. See fig 7.

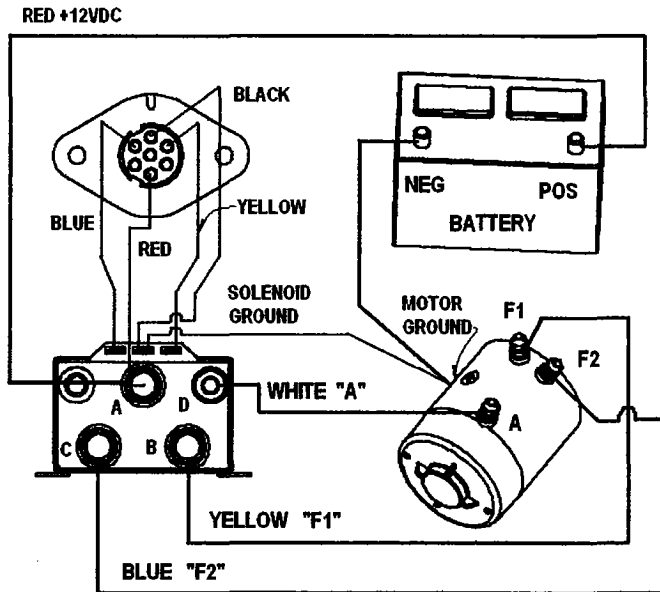
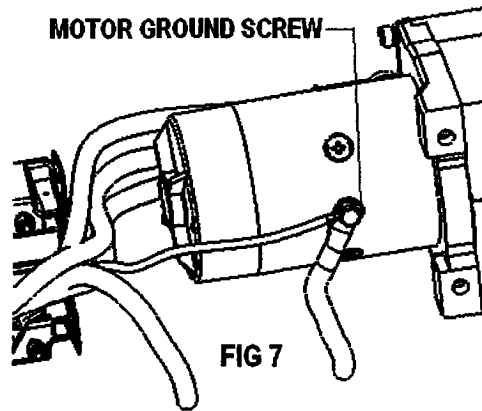
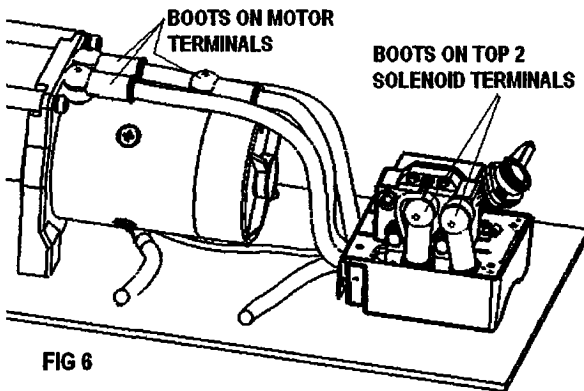

WIRING HOOK UP DIAGRAM

Superwinch, Inc.
Winch Drive
Putnam, CT 06260
U.S.A.
Tel. (860) 928-7787
Fax (860) 963-0811

Superwinch, Ltd.
Abbey Rise, Whitchurch Road
Tavistock, Devon PL 19 9DR
England
Tel. +44 (0) 1822 614101
Fax +44 (0) 1822 615204