

# TOYOTA TUNDRA STEPSIDE INSTALLATION INSTRUCTIONS

Read your owner's manual and these instructions before installing your Toyota Tundra Truxedo® kit.

Follow these instructions to install your TruXedo® side rail clamps and adapter pan. Side rails are notched and pre-bent to conform to your pickup bed.

Item	Part #	Description
1	1703482	Clamp w/Slot, Male
2	1115184	Clamp, Female, Lo Pro
3	1700429	Flat Washer, 3/8"
4	1700369	Cap Screw, 3/8" x 1 3/4"
5	1115745	Plastic Washer, 1/4" x 1 1/2"
6	1701580	Nylon Lock Nut, 3/8"

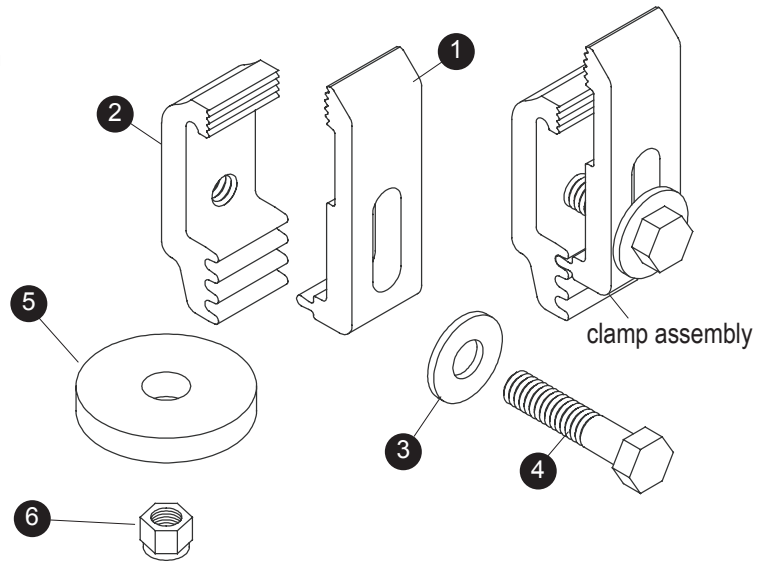

**STEP 1:** A 1/4" x 6" piece of seal is provided to fill the gaps near the bulkhead. This seal should be applied BEFORE the side rails are attached. The following pictures are shown with the side rails attached to illustrate the proper placement of the seal. Cut seal to fit (approx. 4") and place along the area marked by x's in the photo below. (Photos shown are of the TruXedo Lo Pro QT. The rails will look different but placement of the seal is the same.)

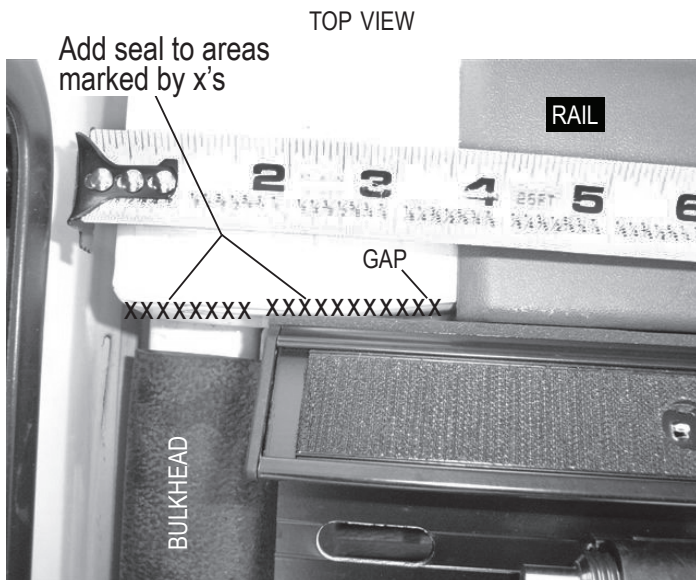

**STEP 2:** Cut another piece of seal and affix it to area marked by x's in the photo below.

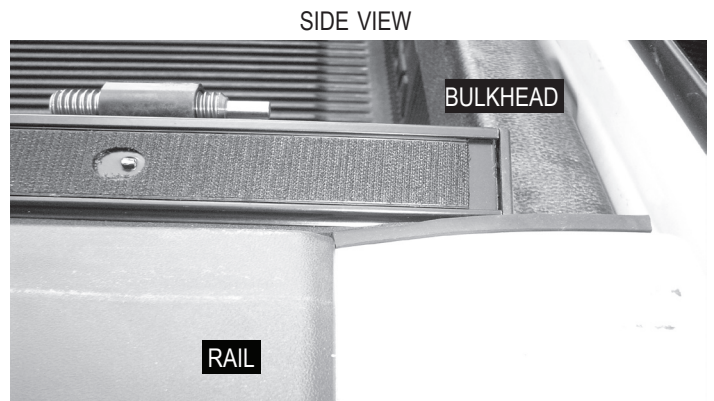
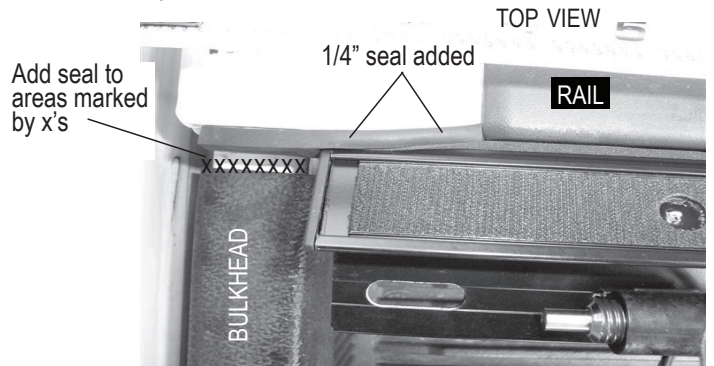

## TruXedo, Inc.

P.O. Box 1078, 2209 Kellen Gross Dr., Yankton, South Dakota 57078  
 Call Toll Free: 1-877-TRUXEDO (1-877-878-9336) Fax: (605) 664-9304  
 Visit Us Online: <http://www.truxedo.com>



P/N 1114881 Rev. F

# TOYOTA TUNDRA STEPSIDE INSTALLATION INSTRUCTIONS CONTINUED

**STEP 3:** Position clamps 9" and 36" from front of box; and 8" and 17" from tailgate (four clamps per side rail).

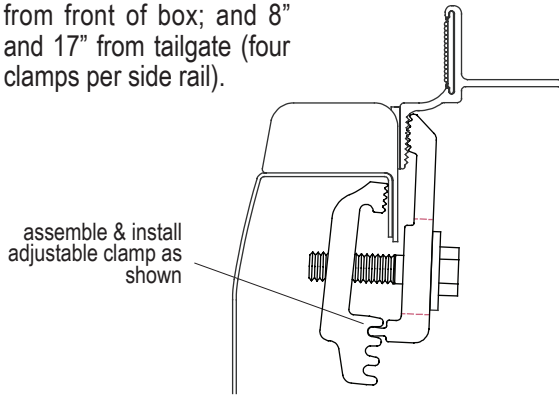

**STEP 4:** Clamp side rails to pickup bed at locations shown.

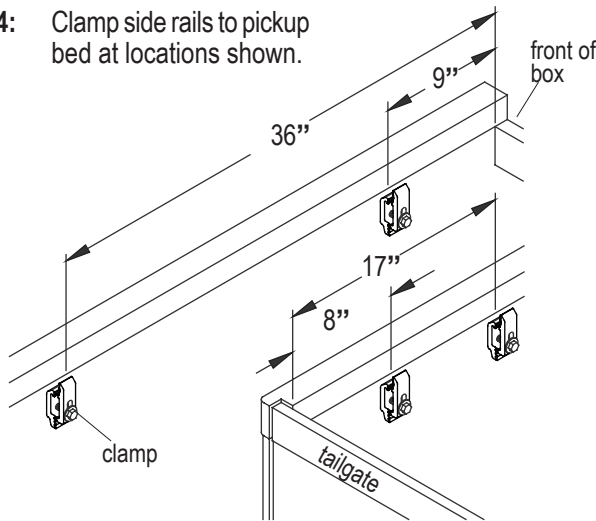

**STEP 5:** Align side rails 1/4" from tailgate, flush with bed rail and level with each other. Tighten clamp assemblies (see owner's manual).

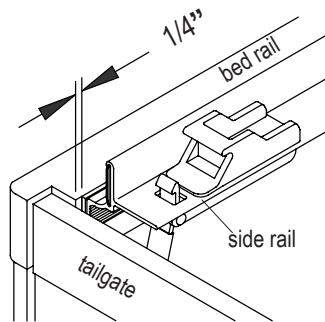

**STEP 6:** Center pan adapter on front header. Fasten 3/8" x 3/4" stove bolts through holes in pan adapter and into square nuts inside header slot. Tighten bolts.

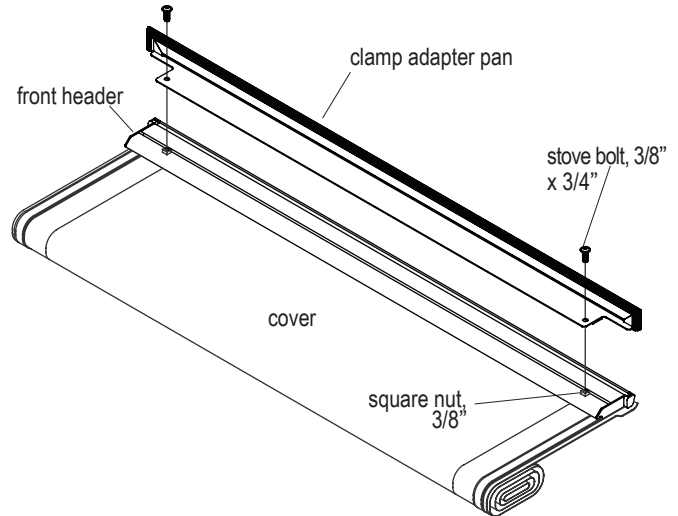

**STEP 7: Front header:** Back spring plunger out. Set cover assembly across cab end of side rails. Insert screws in front header through slots in side rails. Secure with plastic washers and lock nuts, but do not over tighten. Header must be free to slide.

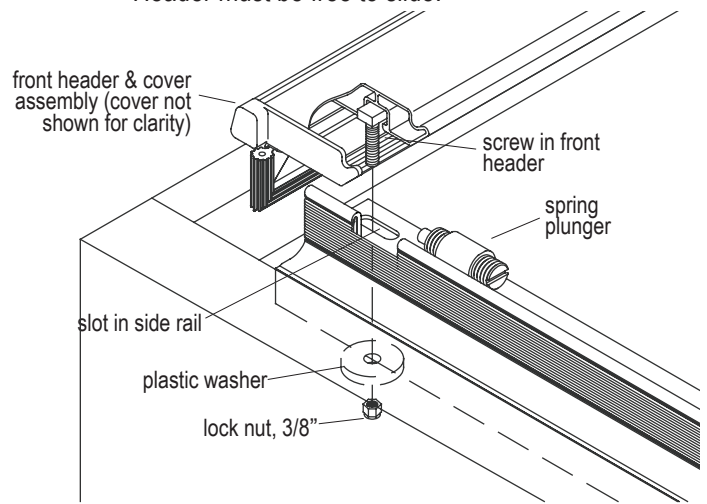

**NOTE:** Refer to owner's manual for cover installation.

**TruXedo, Inc.**

P.O. Box 1078, 2209 Kellen Gross Dr., Yankton, South Dakota 57078  
 Call Toll Free: 1-877-TRUXEDO (1-877-878-9336) Fax: (605) 664-9304  
 Visit Us Online: <http://www.truxedo.com>

**TRUXEDO**  
Yankton, SD 1-877-TRUXEDO

P/N 1114881 Rev. F