

NOTICE

2007 GM W/TRACKS DEUCE INSTALLATION SPECIAL INSTRUCTIONS



CAUTION

Incorrect clamping can cause damage to the vehicle. Clamp **ONLY** where **TWO** layers of sheet metal are present. Do not over tighten clamps.

- 1 Correct Clamping locations:** Place clamps in the locations shown below. See step two for positioning the side rails correctly. With side rail held in place, insert clamp horizontally between the cargo rail and bottom of bed rail. Using a socket with extension, tighten the clamps securely. If your truck has factory or aftermarket side rail protectors see detail A & B below.

NOTE: We recommend additional help to hold rail in position while installing clamps. A socket extension is recommended for tightening clamps.

CAUTION

Tighten clamp assemblies securely on side rails before driving vehicle.

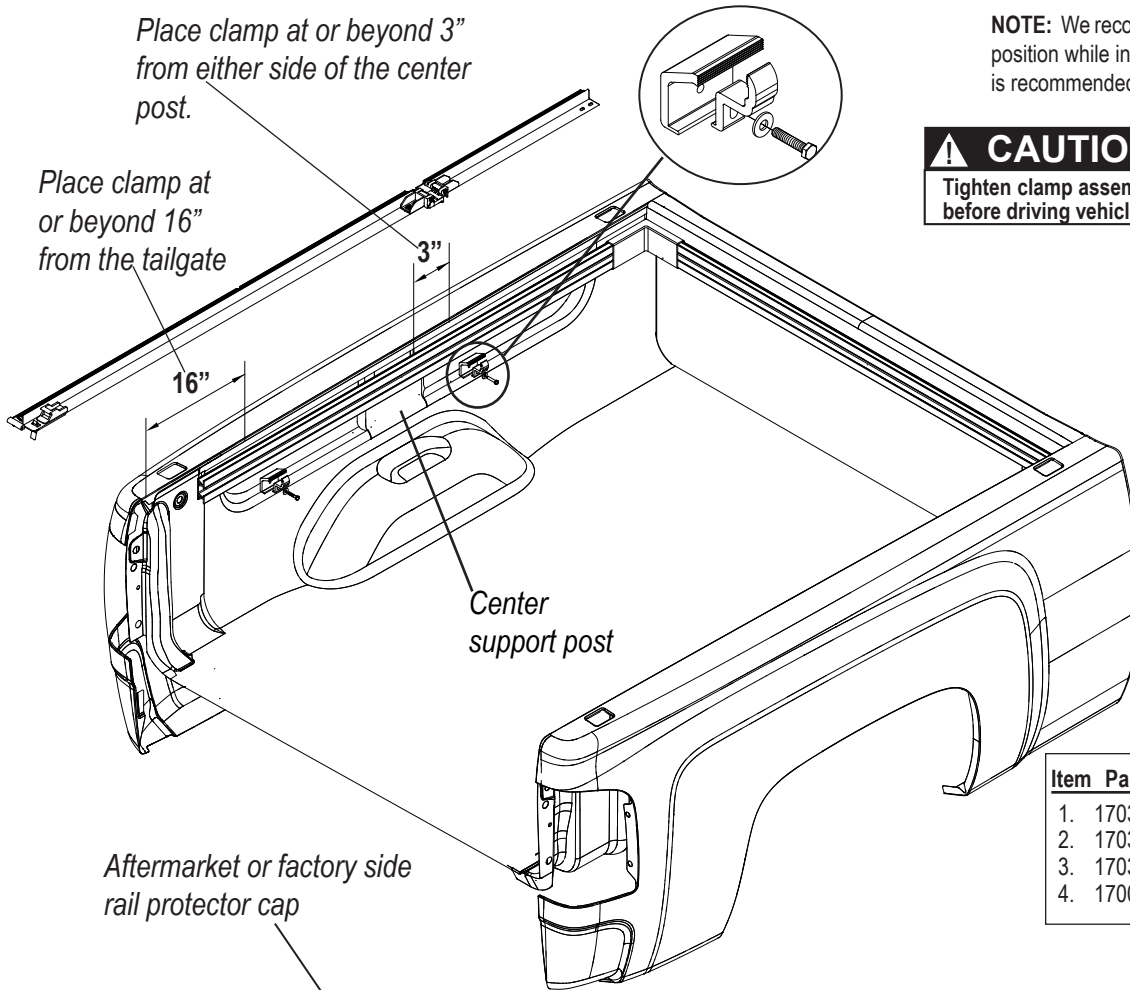

Item	Part #	Description
1.	1703865	MALE CLAMP
2.	1703864	FEMALE CLAMP
3.	1703487	CAP SCREW 5/16" X 1 1/2"
4.	1700428	FLAT WASHER 5/16"

DETAIL A:

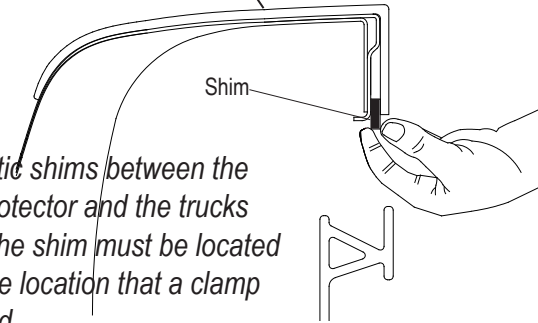

Place plastic shims between the side rail protector and the trucks side rail. The shim must be located at the same location that a clamp will be used.

DETAIL B:

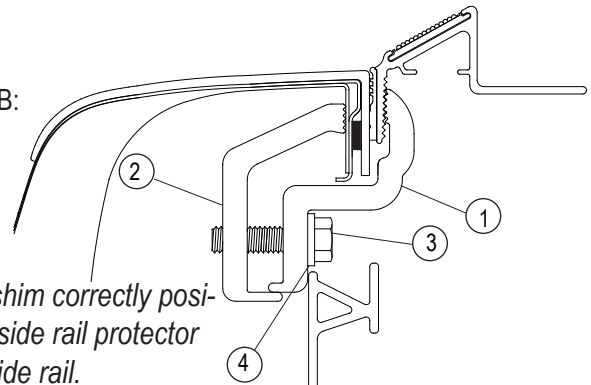

Detail showing shim correctly positioned between side rail protector and the trucks side rail.

2007 GM W/TRACKS DEUCE INSTALLATION INSTRUCTIONS (CONTINUED)

These instructions replace step 1 thru 7 in the Deuce owners manual.

- 2 Install Side Rails:** With tailgate closed, align side rails flush with pickup bed rails and level with each other. Lightly compress D-seal against tailgate. Clamp side rails to bed rails, see step **one** for correct clamp locations. Tighten securely.

High Bed Caps -
Adjust side rail height as needed to get a good seal at front and back of cover.

WARNING Tighten clamps securely on side rails before driving vehicle.

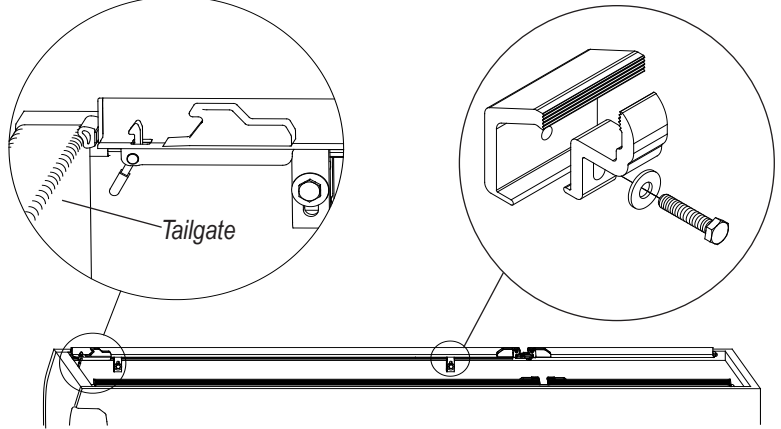

- 3 Install Underbody Rails:** Fold back hinged portion of side rails, and stand inside pickup bed to install underbody rails. Two **plastic shims** and two clamps will be used for each underbody rail.

The underbody rails are marked driver and passenger side. The rails will have weather seal extending out the front of the rail. Place that end toward the front bulkhead. The seal can be trimmed to fit if needed.

See step 4 for correct plastic shim location

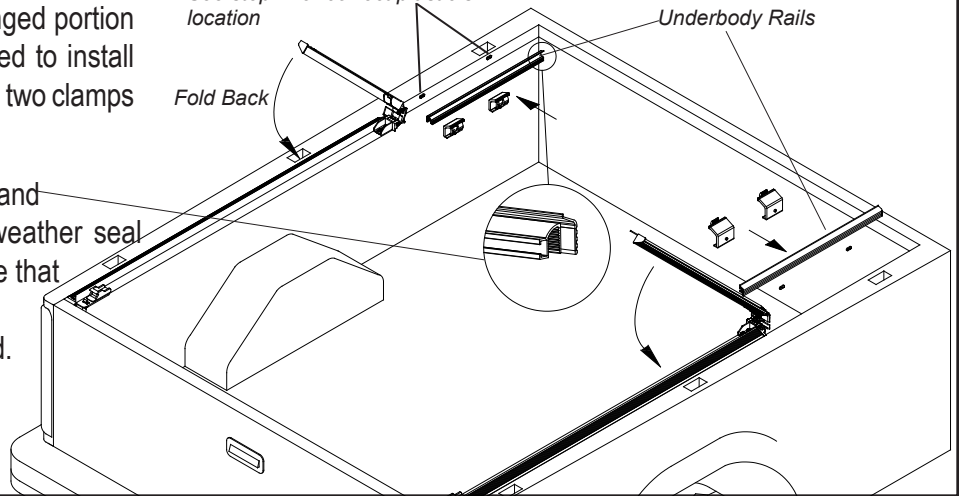

- 4 Install Underbody Rails:** Position underbody rails flush with Truxedo Deuce side rails as shown. Clamp underbody rails to the truck rails. Plastic shims will need to be used in this step.

Align weather seal arc slightly higher than the trucks rail.

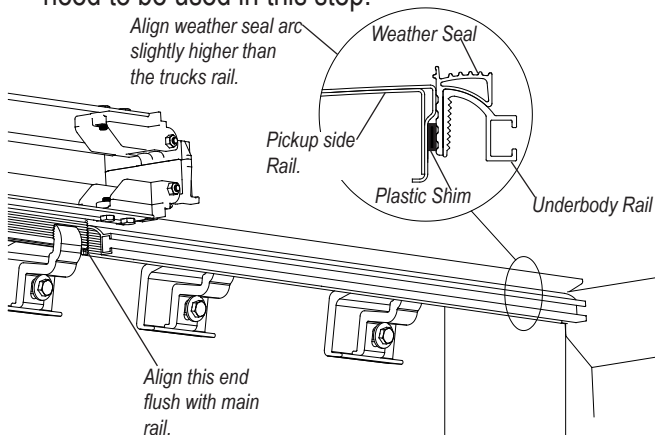

Place shim and clamp at or beyond 11.50" from the bulkhead.

- 5 Install Front Striker:** Temporarily remove plastic corner cover. Install striker fastener (1117153) in the front cargo rail. Assemble the striker bracket (1117150) toward the center of the truck box.

Replace plastic cover after assembly.

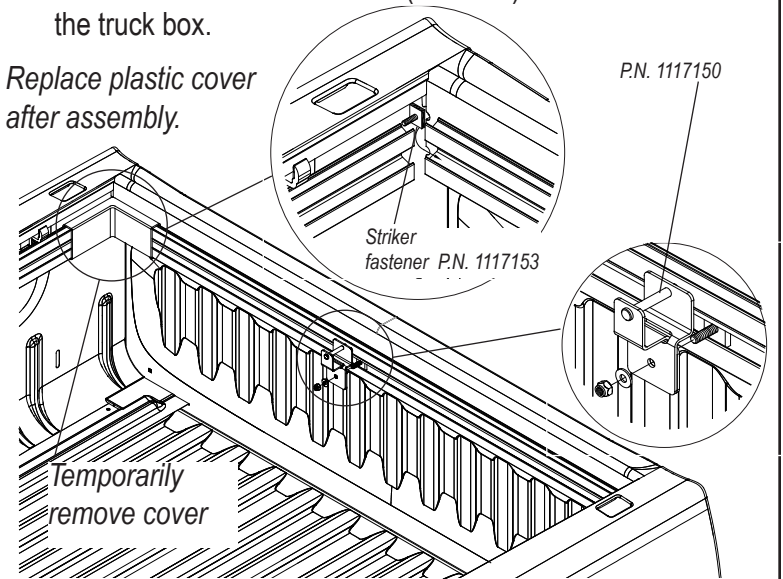

Continue with step 8 in the main Deuce manual.